

6 x 12 m XXL

★★★★★
**PREMIUM
PLUS**

DE Gebrauchsanweisung PVC-Zelt

GB Assembly instruction PVC-Tent

PL Instrukcja obsługi PVC-Namioty







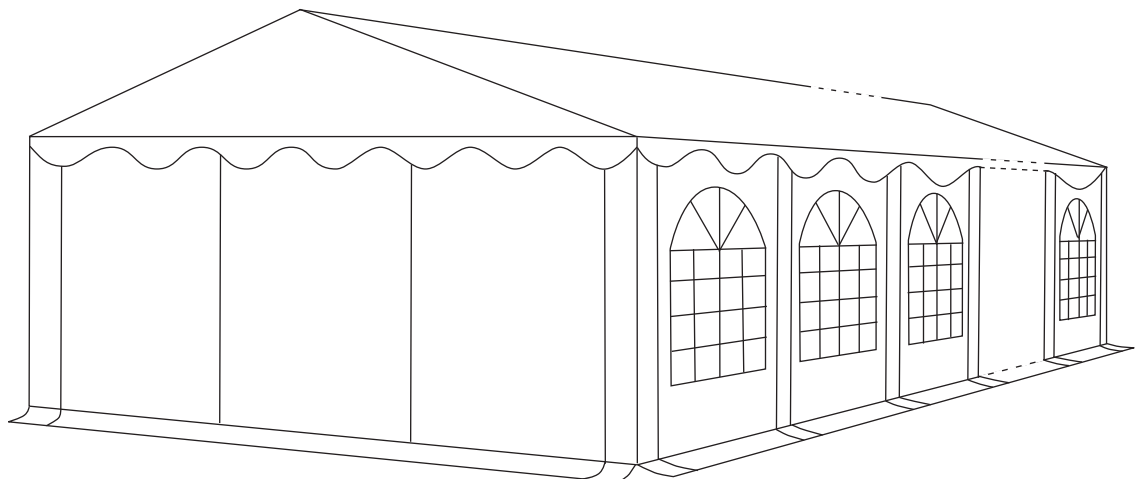





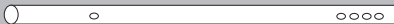

NL Gebruiksaanwijzing PVC-Tent

FR Mode d'emploi Tente PVC

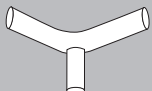

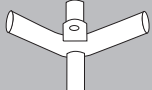



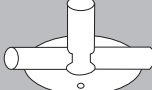

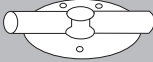
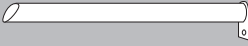

CZ Instrukce PVC Stan

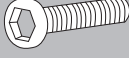
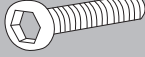
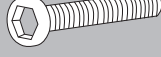

Inhalt

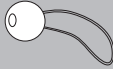
Artikel Nr.	Beschreibung	ID Nummer		6x12m
30411	Stange 1430 mm 50-50	1		28
30513	Stange 1925 mm 38-38	2		38
30413	Stange 1925 mm 38-38 mit Loch	3		4
30514	Stange 1470 mm Dachstrebe 6-Serie horizontal	4		14
30515	Stange 500 mm Dachstrebe 6-Serie vertikal	5		7
30437	Stange 1174 mm 25-25 Diagonalstrebe	6		4
30414	Stange 2488 mm 50-50 mit Löchern	7		10
30415	Stange 2488 mm 50-50 mit Löchern und einem Loch	8		4
30516	Stange 1915 mm 38-38	9		6
30416	3er Eckverbinder 110° 54-43	10		4
30417	3er Eckverbinder 140° 54-42	11		2
30418	4er Eckverbinder 140° 54-42	12		5
30419	4er Eckverbinder 110° 54-42	13		10
30420	Kreuzstück 54-42	14		10
30421	T-Stück 54-42	15		4
30422	3fach Verbinder - Fuß für die Ecken 54-42	16		4
30423	3fach Verbinder - Fuß für die Seitenwände 54-42	17		10

Inhalt

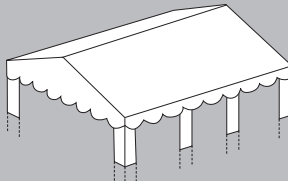
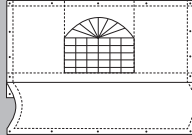
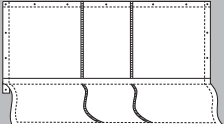
Artikel Nr.	Beschreibung	ID Nummer		6x12m
30424	3fach Verbinder - Fuß für die Endwände 54-42	18		4
30436	Erdnägel 60 cm	19		10
30044	Schraubhaken	20		4
30046	Erdnägel 6x180 mm	21		14
30047	Erdnägel 4x160 mm	22		54
30383	Schraube 10 mm	23		184
30384	Schraube 30 mm	24		28
30404	Schraube 45 mm	25		4
30405	Schraube 65 mm	26		4
30052	Flügelmutter	27		28
30407	Hutmutter	28		8
30430	Gummischlaufe 14 cm type 1	29		196
30429	Gummischlaufe 5 cm type 1	30		26
30050	Spannleine 3 m	31		4
30051	Dachhaken	32		14
	Dach	33		1
	Seitenwand	34		12
	Endwand	35		2

Gebrauchsanweisung

1 Suchen Sie einen ebenen Untergrund für das Zelt. Packen Sie die Kartons aus und sehen Sie nach, ob auch alle hier aufgelisteten Teile vorhanden sind.

Setzen Sie den Rahmen für das Dach zusammen indem Sie die Teile 10 bis 15 an die Stangen (Teile 1,2 u. 3) montieren und zur Fixierung mit den Schrauben fest anziehen.

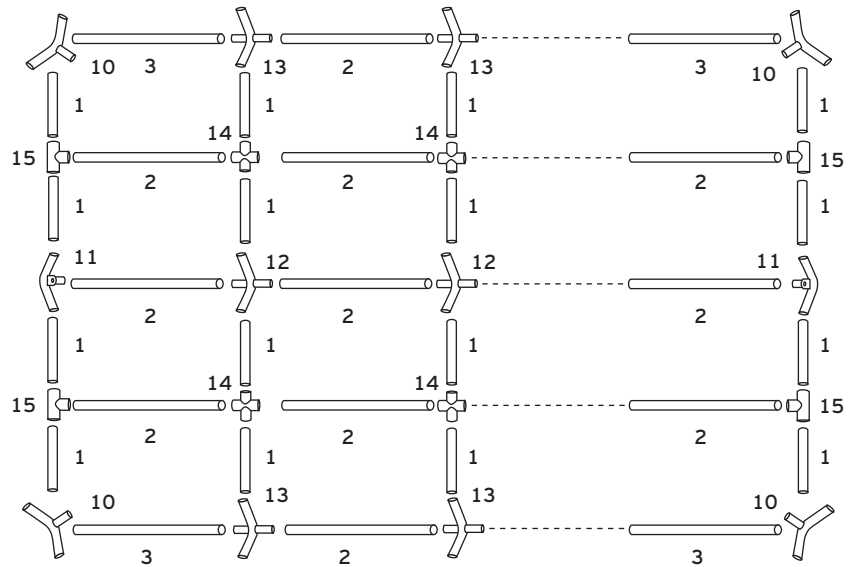

2 Befestigen Sie die Verstärkungsstreben (Teile 4 u. 5) mit Schrauben (24) und Flügelmutter (27).

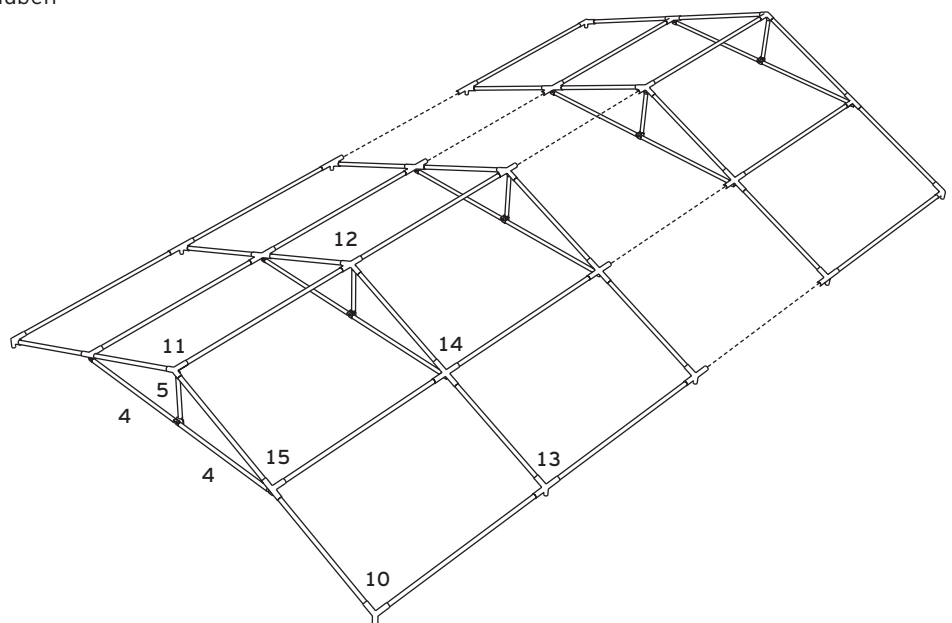

- 3** Heben Sie eine Seite des Zeltgerüsts an und setzen Sie die Beine (7) ein. Wobei das Bein mit der Nummer 8 jeweils Außen in allen vier Ecken eingesetzt werden muss. Setzen Sie das Dach (33) auf den Rahmen und befestigen Sie es mit den Gummischlaufen (30). Achten Sie darauf, nicht zu viel Spannung auf die Gummischlaufen zu geben, um das Anbringen der anderen Seite nicht zu erschweren.

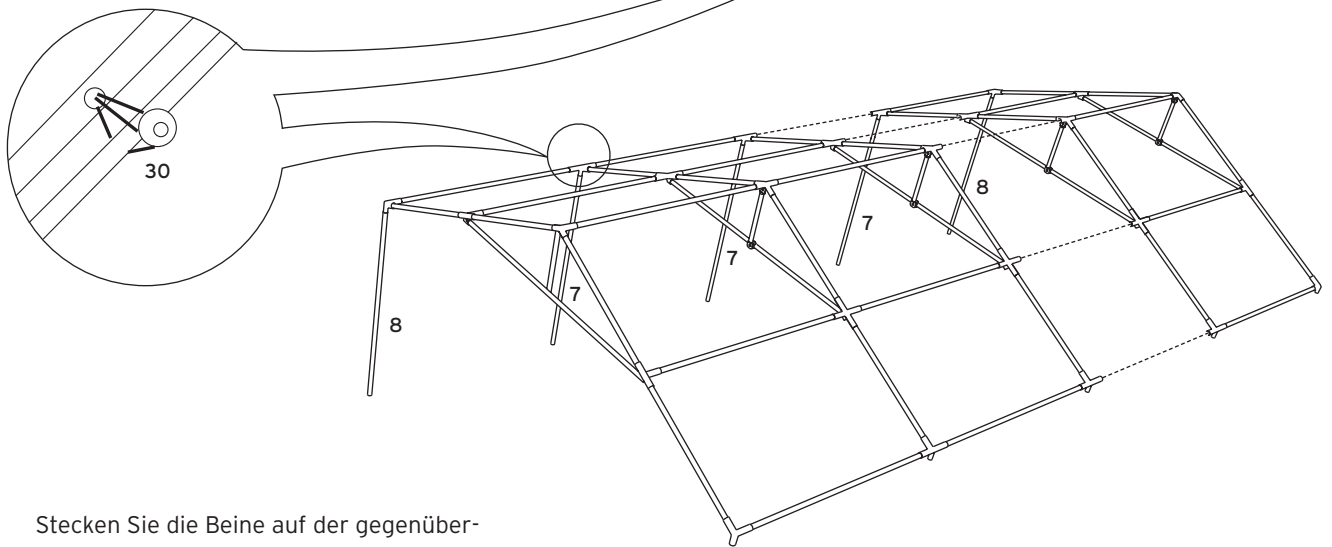
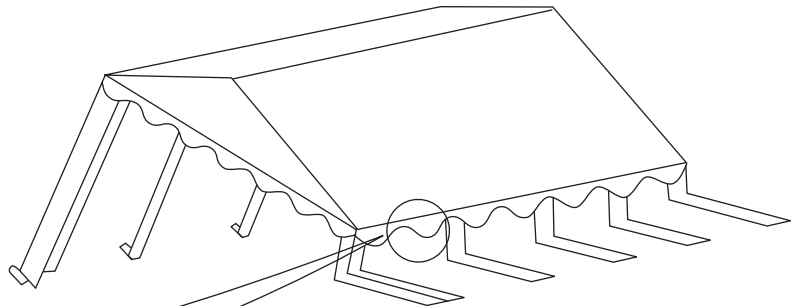

- 4** Stecken Sie die Beine auf der gegenüberliegenden Seite ein und montieren Sie an den unteren Enden die FüÙe (16, 17). Benutzen Sie die langen Erdnägel (21) um die FüÙe am Boden zu befestigen. Die Dachschals werden mit Haken (32) an den Stangen (7, 8) befestigt. Verstärken Sie den Seitenrahmen indem Sie an allen vier Eckelementen die Querstreben (6) einsetzen. Anschließend vervollständigen Sie den Bodenrahmen mit den entsprechenden Stangen (2, 3 u. 9)/Verbinder (18).

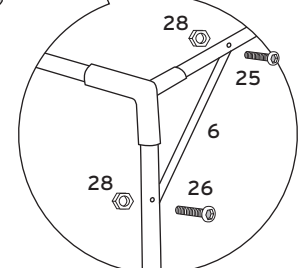
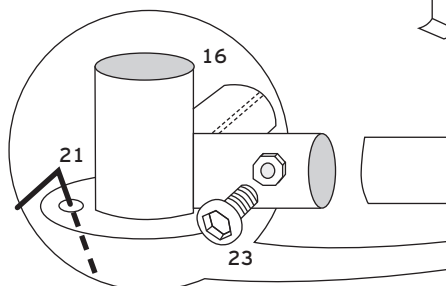
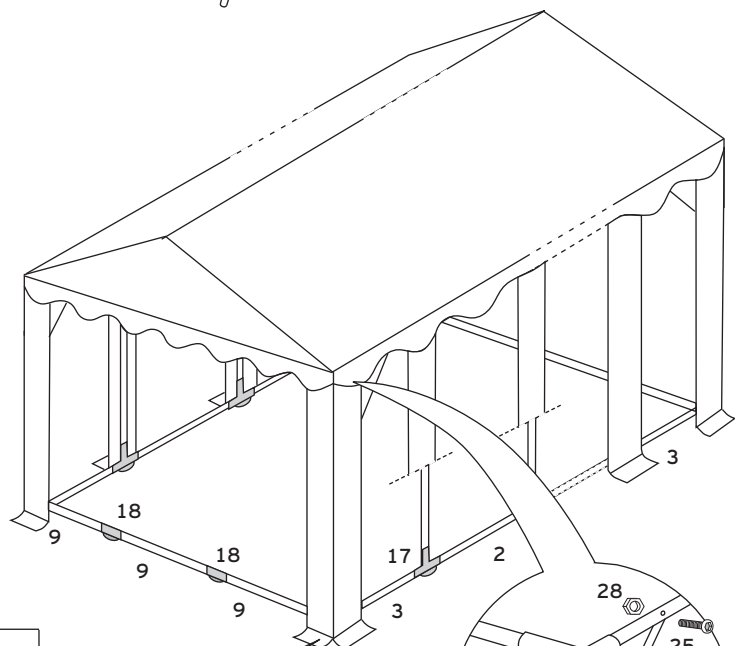

- 5** Breiten Sie die Seitenwände (34) und Endwände (35) aus und befestigen Sie die Seitenwände mit den Gummischlaufen (29) am Gerüst und die Endwände mit den kurzen Gummischlaufen (30) direkt am Dach. Mit den kurzen Erdnägeln (22) befestigen Sie die Endwände am Boden. Die Spannleine läuft von jeder Ecke des Zelt und wird mit dem Schraubhaken (20) am Boden verspannt. Zusätzliche Spannung bzw. Stabilität bekommt das Zelt durch den Einsatz der Profierdnägel (20).

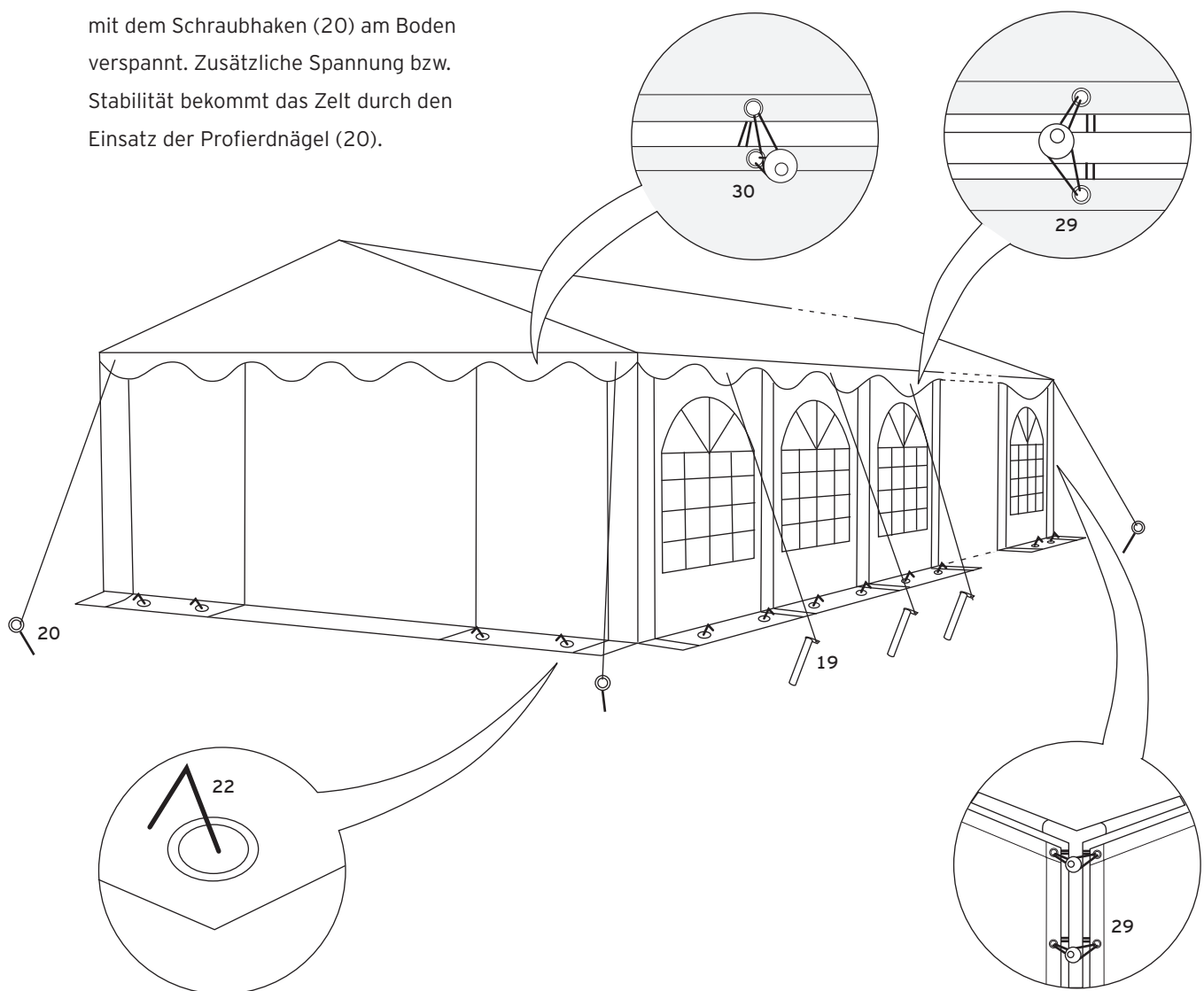

Reinigung und Wartung













Dach und Seitenteile lassen sich mit Seifenlauge abwaschen. Schimmel und Stockflecken entfernen Sie mit einer milden Chlorlösung. Befolgen Sie die Anweisungen des Herstellers und testen Sie die Chlorlösung an einer nicht sichtbaren Stelle, um sicherzugehen, dass keine Verfärbungen auftreten.

Achtung! Das Partyzelt darf nicht im nassen Zustand zusammengelegt und verpackt werden. Lassen Sie es vorher vollständig trocknen.



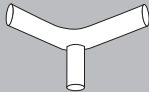

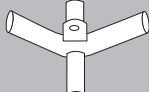
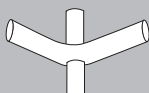

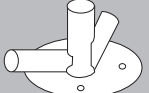
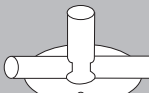

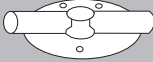
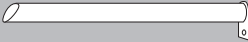

Warnung

1. Bitte achten Sie darauf, das Zelt vorsichtig zu behandeln, um Defekte zu vermeiden.
2. Das Gestänge nicht zu kräftig behandeln, da dies ansonsten Beschädigt werden könnte.
3. Zelte sind als temporäre Unterkunft gedacht und sollten bei widrigen Witterungsverhältnissen abgebaut werden.
4. Bitte wählen Sie immer einen geeigneten Abstand zu Schläuchen, Gas- oder Elektroleitungen, um diese nicht zu beschädigen.
5. Beim Einsatz geeigneter Heizgeräte (z. B. Auskunft im Fachhandel) ist ein Abstand von mindestens 1,2 m zu jeglichem Planenmaterial zu beachten. Offenes Feuer sowie Heizgeräte mit offenen Flammen wie Heizpilze, Terrassenstrahler, Gasheizer etc. sollten auf keinen Fall verwendet werden.
6. Der Aufbauer ist verantwortlich für die angemessene Verankerung und damit für die Sicherheit des Zelt.

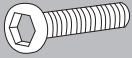
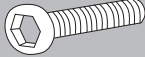
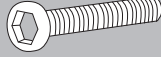
Contents

Part no.	Description	ID no.		6x12m
30411	pipe 1430 mm 50-50	1		28
30513	pipe 1925 mm 38-38	2		38
30413	pipe 1925 mm 38-38 with hole	3		4
30514	pipe 1470 mm roof brace 6-series horizontal	4		14
30515	pipe 500 mm roof brace 6-series vertical	5		7
30437	pipe 1174 mm 25-25 diagonal pipe	6		4
30414	pipe 2488 mm 50-50 with holes	7		10
30415	pipe 2488 mm 50-50 with holes and a hole	8		4
30516	pipe 1915 mm 38-38	9		6
30416	connector three way 110° 54-43	10		4
30417	connector three way 140° 54-42	11		2
30418	connector four way 140° 54-42	12		5
30419	connector four way 110° 54-42	13		10
30420	cross piece 54-42	14		10
30421	T-piece 54-42	15		4
30422	connector three way - foot for the corners 54-42	16		4
30423	connector three way - foot for the side walls 54-42	17		10

Contents

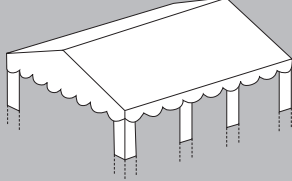
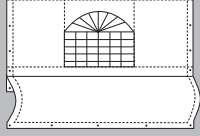
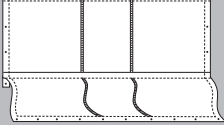
Part no.	Description	ID no.		6x12m
30424	connector two way - foot for the end walls 54-42	18		4
30436	ground pegs 60 cm	19		10
30044	screw hook	20		4
30046	ground peg 6x180 mm	21		14
30047	ground peg 4x160 mm	22		54
30383	screw 10 mm	23		184
30384	screw 30 mm	24		28
30404	screw 45 mm	25		4
30405	screw 65 mm	26		4
30052	wing nut	27		28
30407	cap nut	28		8
30430	bungee 14 cm type 1	29		196
30429	bungee 5 cm type 1	30		26
30050	guy rope 3 m	31		4
30051	roof hook	32		14
	roof	33		1
	side wall	34		12
	end wall	35		2

Instructions

1 Select a flat surface for the tent. Unpack the boxes and check if all listed parts are included.

Assemble the roof frame by mounting parts 10 to 15 on the pipes (parts 1, 2, and 3). Use the screws to firmly attach the parts.

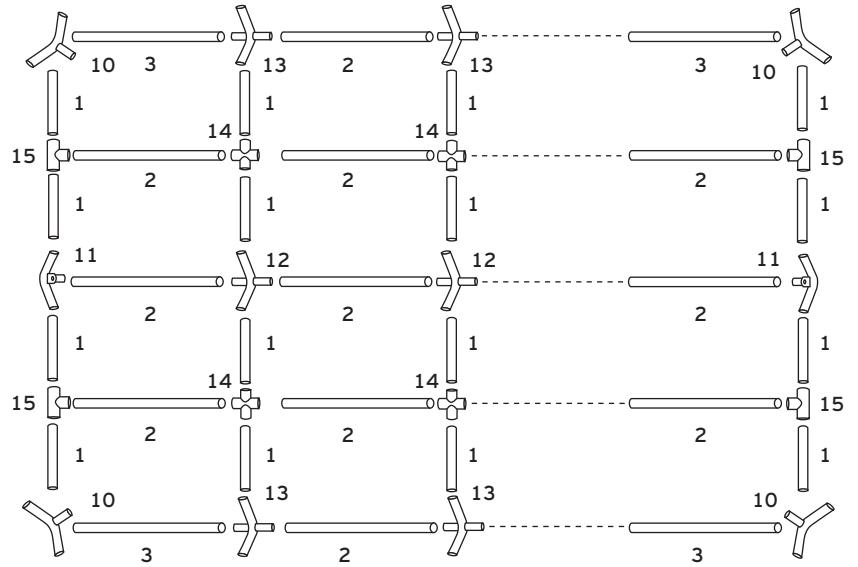

2 Attach the reinforcement braces (parts 4 and 5) using screws (24) and wing nuts (27).

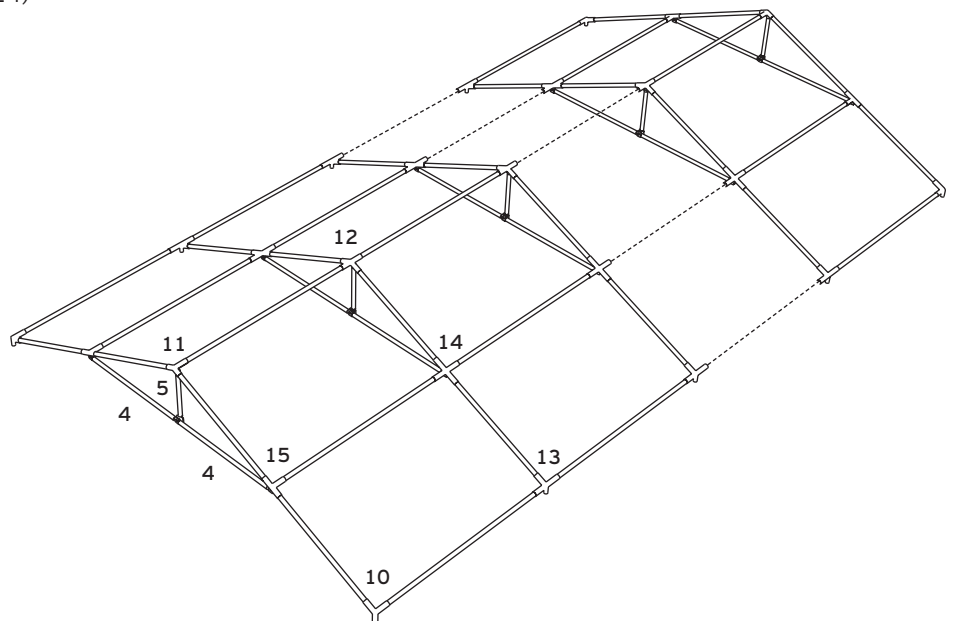

- 3** Lift one side of the tent frame and attach the legs (7). Attach the legs with part no. 8 to the outside in all four corners. Place the roof (33) onto the frame and use the bungees (30) to fasten it. Be sure not to put too much tension on the bungees in order not to make attaching the other side more difficult.

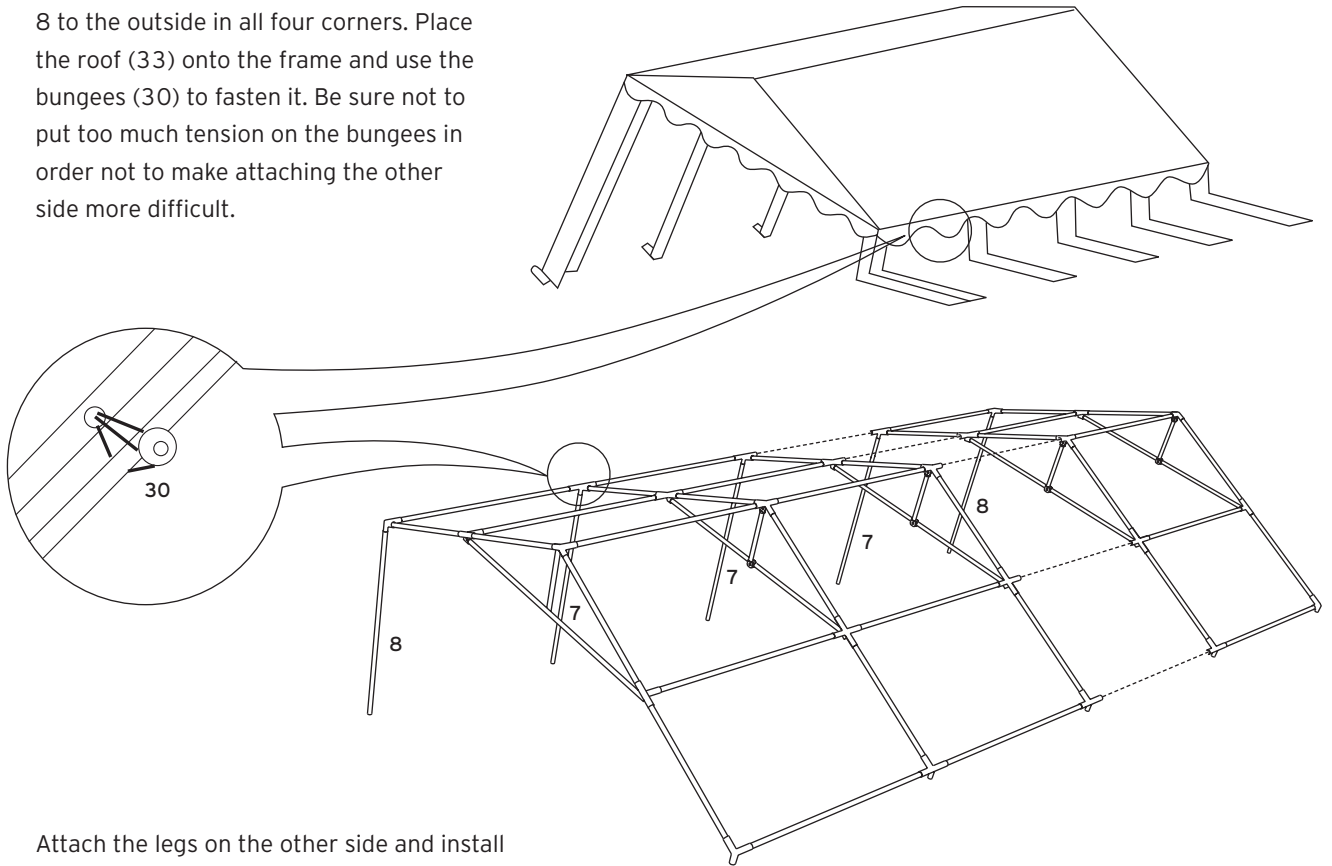

- 4** Attach the legs on the other side and install the feet (16, 17) at the bottom. Use the long ground pegs (21) to fasten the feet to the ground. Attach the side covers to the pipes (7, 8) using hooks (32). Reinforce the side frame by attaching the diagonal pipes (6) to all four corners. Complete the bottom frame with the required pipes (2, 3, and 9) and connector (18).

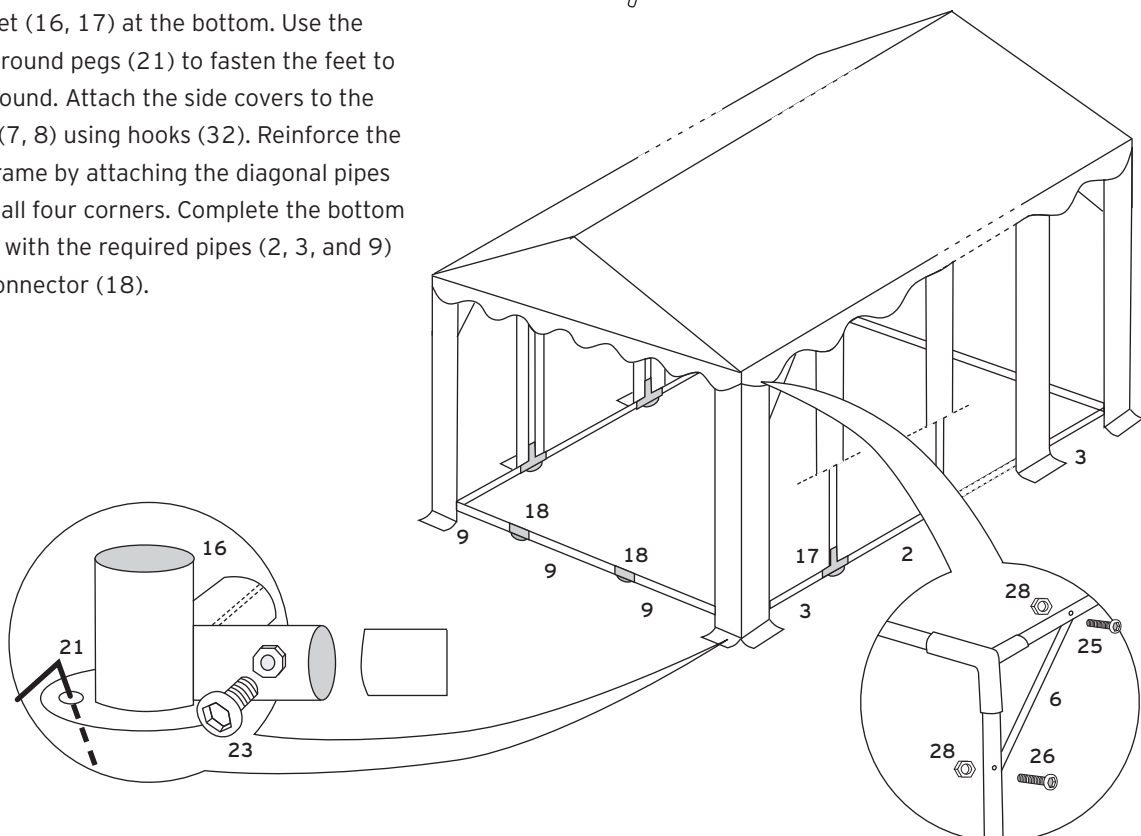

- 5** Extend the side walls (34) and the end walls (35) and attach the side walls to the frame using the bungees (29). Attach the end walls directly to the roof using the short bungees (30). Use the short ground pegs (22) to fasten the end walls to the ground. The guy rope runs from every corner of the tent and is braced to the ground using the screw hooks (20). The professional ground pegs (20) provide the tent with additional tension and stability.

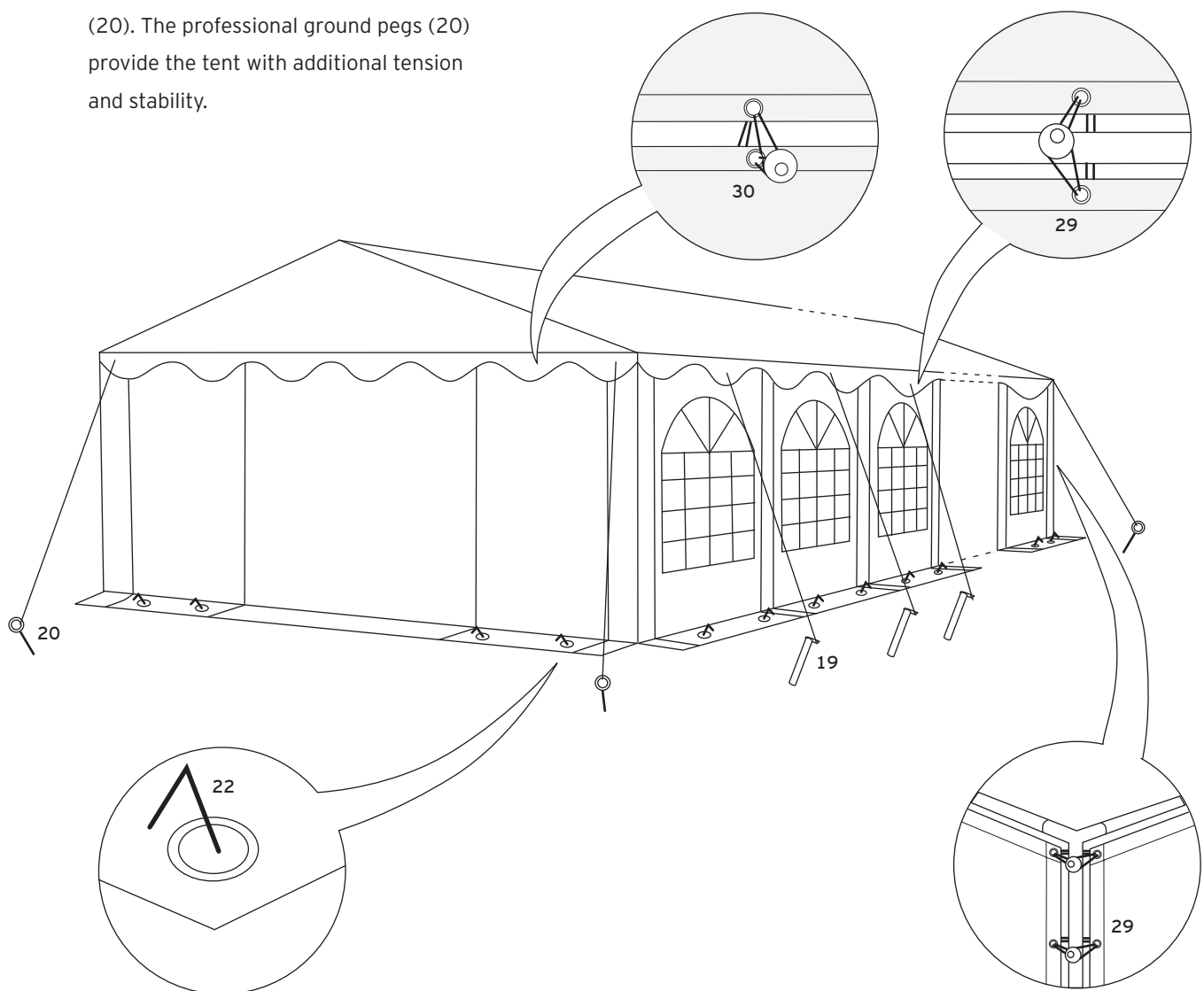

Cleaning and maintenance













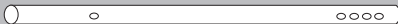

Wash off the roof and the side parts with soapy water. Mould and mould stains can be removed using a mild chlorine solution. Observe the instructions provided by the manufacturer and test the chlorine solution on a hidden spot to make sure that there is no discolouration.

Caution! The party tent must not be collapsed and packed up when it is wet. First, allow it to dry completely.

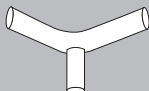

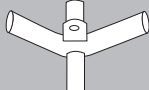



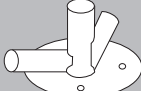
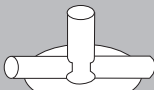

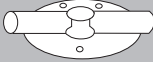
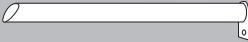

Caution

1. Always handle the tent with care to avoid damage.
2. Do not apply too much pressure to the frame parts to avoid damage.
3. Tents are intended for temporary accommodation and should be taken down in adverse weather conditions.
4. Always be sure to keep sufficient distance to hoses as well as gas and power lines to avoid possible damage.
5. When using suitable heaters (available e.g. in specialist shops), keep a minimum distance of 1.2 m to tarp material. Open fire or heaters with open flames such as patio heaters, umbrella heaters, gas heaters etc. should not be used in any case.
6. The person setting up the tent is responsible for adequately securing it to ensure its safety.

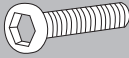
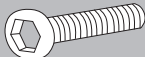
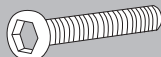
Zawartość

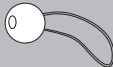
Nr kat.	Opis	Nr ID		6 x 12 m
30411	Drażek 1430 mm 50-50	1		28
30513	Drażek 1925 mm 38-38	2		38
30413	Drażek 1925 mm 38-38 z otworem	3		4
30514	Drażek 1470 mm Wspornik dachu seria 6, poziomy	4		14
30515	Drażek 500 mm Wspornik dachu seria 6, pionowy	5		7
30437	Drażek 1174 mm 25-25 Poprzeczka	6		4
30414	Drażek 2488 mm 50-50 z otworami	7		10
30415	Drażek 2488 mm 50-50 z otworami oraz z jednym osobnym otworem	8		4
30516	Drażek 1915 mm 38-38	9		6
30416	Łącznik narożny potrójny 110° 54-43	10		4
30417	Łącznik narożny potrójny 140° 54-42	11		2
30418	Łącznik narożny poczwórny 140° 54-42	12		5
30419	Łącznik narożny poczwórny 110° 54-42	13		10
30420	Czwórnik 54-42	14		10
30421	Trójnik 54-42	15		4
30422	Łącznik potrójny – stopka do narożników 54-42	16		4
30423	Łącznik potrójny – stopka do ścian bocznych 54-42	17		10

Zawartość

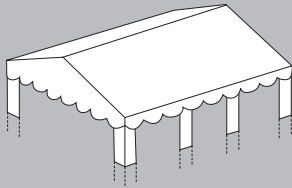
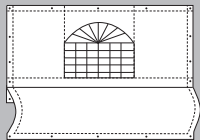
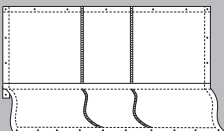
Nr kat.	Opis	Nr ID		6 x 12 m
30424	Łącznik potrójny – stopka do ścian szczytowych 54-42	18		4
30436	Szpilka 60 cm	19		10
30044	Hak wkręcany	20		4
30046	Szpilka 6 x 180 mm	21		14
30047	Szpilka 4x160 mm	22		54
30383	Śruba 10 mm	23		184
30384	Śruba 30 mm	24		28
30404	Śruba 45 mm	25		4
30405	Śruba 65 mm	26		4
30052	Nakrętka motylkowa	27		28
30407	Nakrętka kołpakowa	28		8
30430	Pętelka gumowa 14 cm typ 1	29		196
30429	Pętelka gumowa 5 cm typ 1	30		26
30050	Linka naciągowa 3 m	31		4
30051	Hak dachu	32		14
	dachu	33		1
	Ściana boczna	34		12
	Ściana szczytowa	35		2

Instrukcja montażu

1 Znajdź płaską powierzchnię do rozstawienia namiotu. Rozpakuj kartony i sprawdź, czy zawierają wszystkie wymienione tutaj elementy.

Zmontuj ramę dachu. W tym celu połącz elementy 10 do 15 z drążkami (elementy 1, 2 i 3) i dokręć je mocno śrubami.

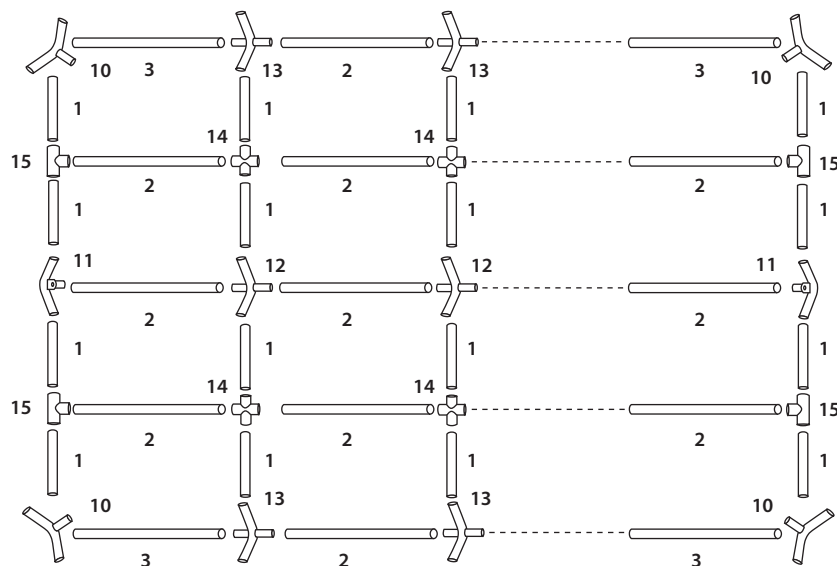

2 Za pomocą śrub (24) i nakrętek motylkowych (27) zamocuj wsporniki wzmacniające (elementy 4 i 5).

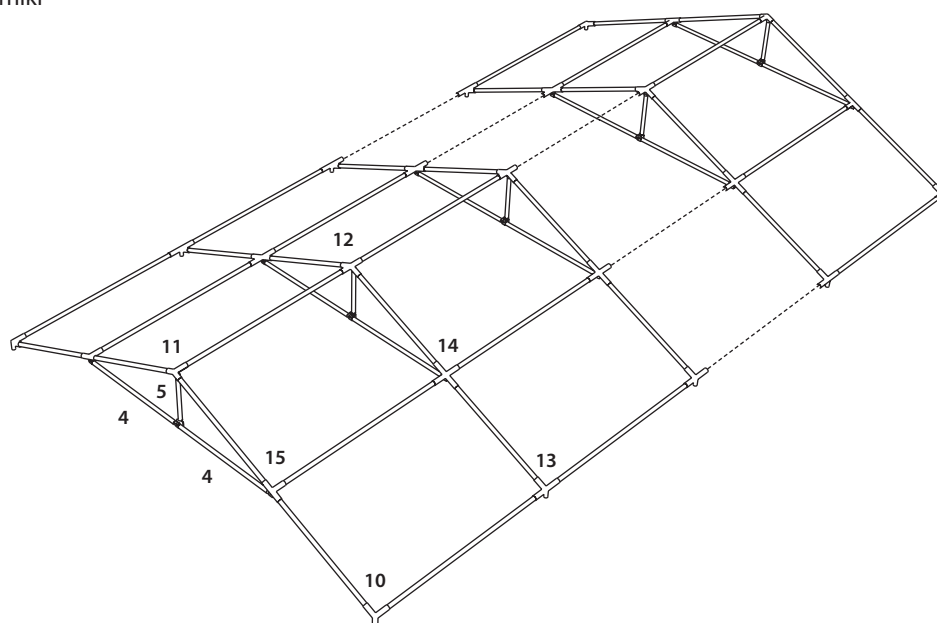

3 Podnieś jedną stronę stelażu namiotu i zamocuj nogi (7). Przy tym noga oznaczona numerem 8 musi się zawsze znajdować na zewnątrz, we wszystkich czterech narożnikach. Nałóż dach (33) na ramę i przymocuj go za pomocą gumowych pętelek (30). Uważaj, aby pętelki nie były za bardzo naprężone, ponieważ mogłoby to utrudnić montaż drugiej strony namiotu.

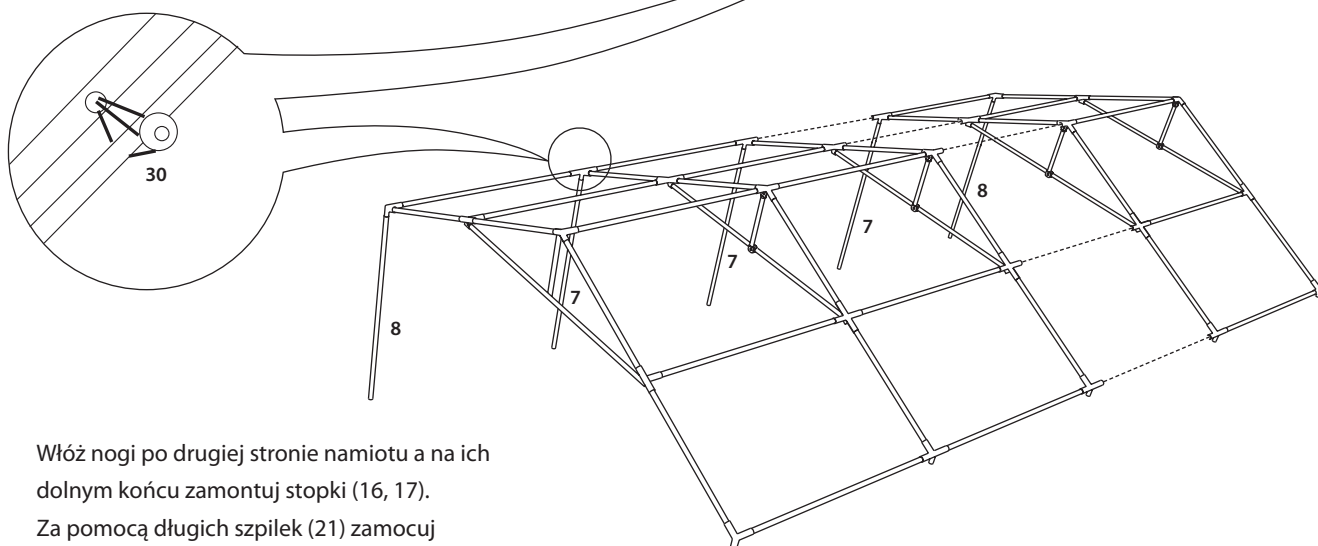
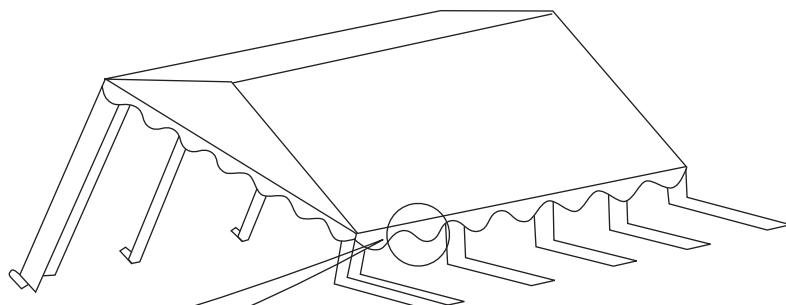

4 Włóż nogi po drugiej stronie namiotu a na ich dolnym końcu zamontuj stopki (16, 17). Za pomocą długich szpilek (21) zamocuj stopki do podłoża. Szlufki dachu przymocuj do drążków (7, 8) za pomocą haków (32). Wzmocnij ramę boczną, zakładając poprzeczki (6) na wszystkich czterech elementach narożnych. Następnie zmontuj ramę podstawy namiotu, używając odpowiednich drążków (2, 3 i 9) i łączników (18).

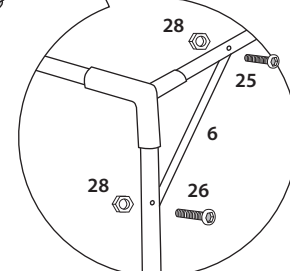
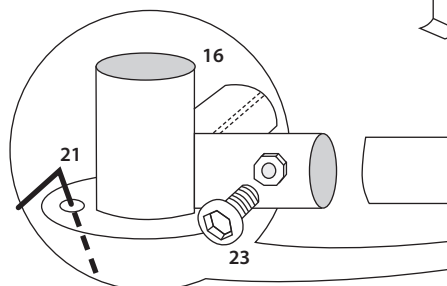
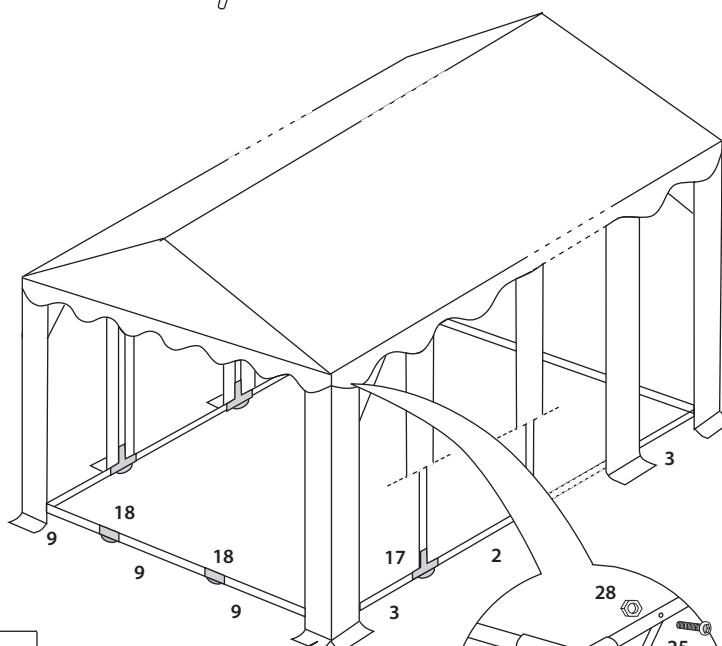

- 5** Rozłóż ściany boczne (34) i ściany szczytowe (35). Ściany boczne zamocuj za pomocą gumowych pętelek (29) do stelaża, a ściany szczytowe za pomocą krótszych gumowych pętelek (30) bezpośrednio do dachu. Za pomocą krótszych szpilek (22) przymocuj ściany szczytowe do podłoża. W każdym narożniku namiotu naciągnij linkę naciągową i zamocuj ją do podłoża za pomocą wkręcanego haka (20). Stosując profesjonalne szpilki (20), uzyskuje się lepsze napięcie / stabilność namiotu.

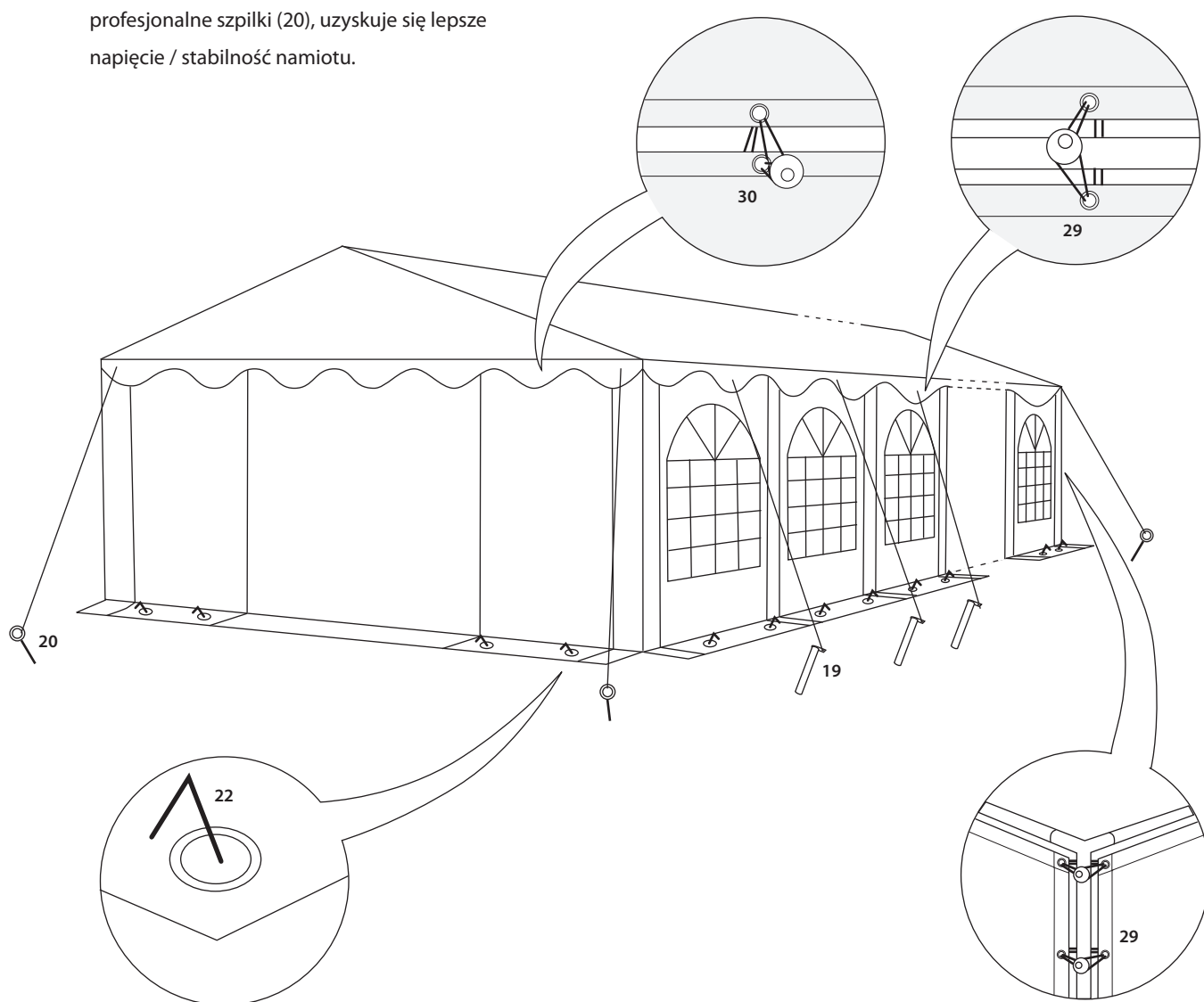

Czyszczenie i konserwacja













Dach i ściany boczne można myć wodą z mydłem. Ślady pleśni i plamy usuwać słabym roztworem chloru. Przestrzegać wskazówek producenta. Aby wykluczyć ryzyko powstania odbarwień, roztwór wypróbować najpierw w niewidocznym miejscu.

Uwaga! Nie wolno składać i pakować wilgotnego namiotu. Przed złożeniem namiot musi całkowicie wyschnąć.



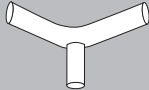

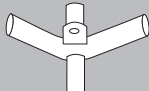
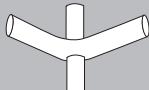

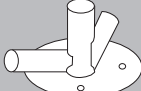
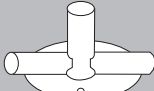

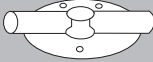
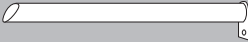

Ostrzeżenie

1. Należy zachować ostrożność podczas rozstawiania i składania namiotu, aby uniknąć jego uszkodzenia.
2. Stelaża nie narażać na zbyt duże obciążenia, ponieważ mogłoby to spowodować jego uszkodzenie.
3. Namioty są przeznaczone do użytku czasowego i w przypadku niesprzyjających warunków atmosferycznych należy je zdemontować.
4. Namiot rozstawiać w odpowiedniej odległości od przewodów wodnych, gazowych i elektrycznych, aby ich nie uszkodzić.
5. W przypadku używania odpowiednich grzejników (np. poprosić o radę sprzedawcę) należy je ustawiać w odległości nie mniejszej niż 1,2 metra od plandeki. Pod żadnym pozorem nie wolno używać otwartego ognia ani grzejników z otwartym płomieniem, np. parasoli grzewczych, promienników ogrodowych, nagrzewnic gazowych itp.
6. Osoba rozstawiająca namiot jest odpowiedzialna za jego właściwe przytwierdzenie do podłoża i tym samym za bezpieczeństwo.

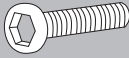
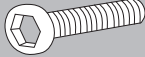
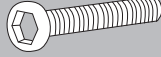
Inhoud

Artikelnr.	Beschrijving	ID-nummer		6x12m
30411	Stang 1430 mm 50-50	1		28
30513	Stang 1925 mm 38-38	2		38
30413	Stang 1925 mm 38-38 met gat	3		4
30514	Stang 1470 mm Daksteun 6-Serie horizontaal	4		14
30515	Stang 500 mm Daksteun 6-Serie verticaal	5		7
30437	Stang 1174 mm 25-25 Diagonale stijl	6		4
30414	Stang 2488 mm 50-50 met gaten	7		10
30415	Stang 2488 mm 50-50 met gaten en een gat	8		4
30516	Stang 1915 mm 38-38	9		6
30416	3-voud. verbinding 110° 54-43	10		4
30417	3-voud. verbinding 140° 54-42	11		2
30418	4-voud. verbinding 140° 54-42	12		5
30419	4-voud. verbinding 110° 54-42	13		10
30420	Kruisstuk 54-42	14		10
30421	T-stuk 54-42	15		4
30422	3-voud. verbinding - voet voor de hoeken 54-42	16		4
30423	3-voud. verbinding - voet voor de zijwanden 54-42	17		10

Inhoud

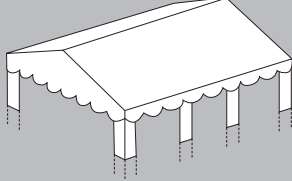
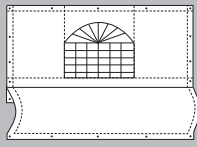
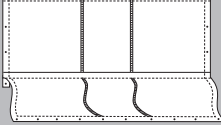
Artikelnr.	Beschrijving	ID-nummer		6x12m
30424	3-voud. verbinding - voet voor de eindwanden 54-42	18		4
30436	Aardpennen 60 cm	19		10
30044	Schroefhaken	20		4
30046	Aardpen 6x180 mm	21		14
30047	Aardpen 4x160 mm	22		54
30383	Schroef 10 mm	23		184
30384	Schroef 30 mm	24		28
30404	Schroef 45 mm	25		4
30405	Schroef 65 mm	26		4
30052	Vleugelmoer	27		28
30407	Dopmoer	28		8
30430	Rubberen lus 14 cm type 1	29		196
30429	Rubberen lus 5 cm type 1	30		26
30050	Spanlijn 3 m	31		4
30051	Dakhaken	32		14
	Dak	33		1
	Zijwand	34		12
	Eindwand	35		2

Gebruiksaanwijzing

1 Zoek een egale ondergrond voor de tent. Pak de het karton uit en controleer of alle hier opgesomde onderdelen aanwezig zijn.

Stel het frame voor het dak samen door de delen 10 tot 15 aan de stangen (delen 1,2 en 3) te monteren en ter bevestiging de schroeven vast aan te draaien.

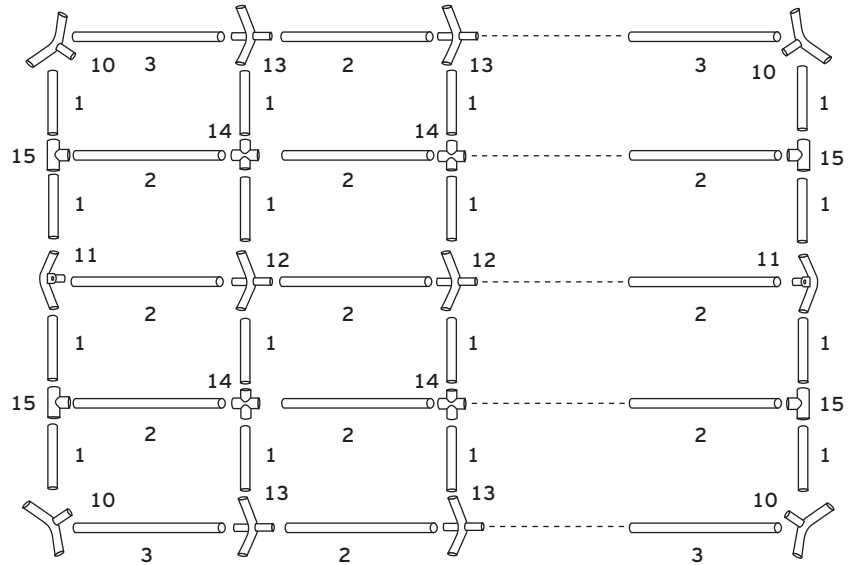

2 Bevestig de versterkingsstijlen (delen 4 en 5) met schroeven (24) en vleugelmoeren (27).

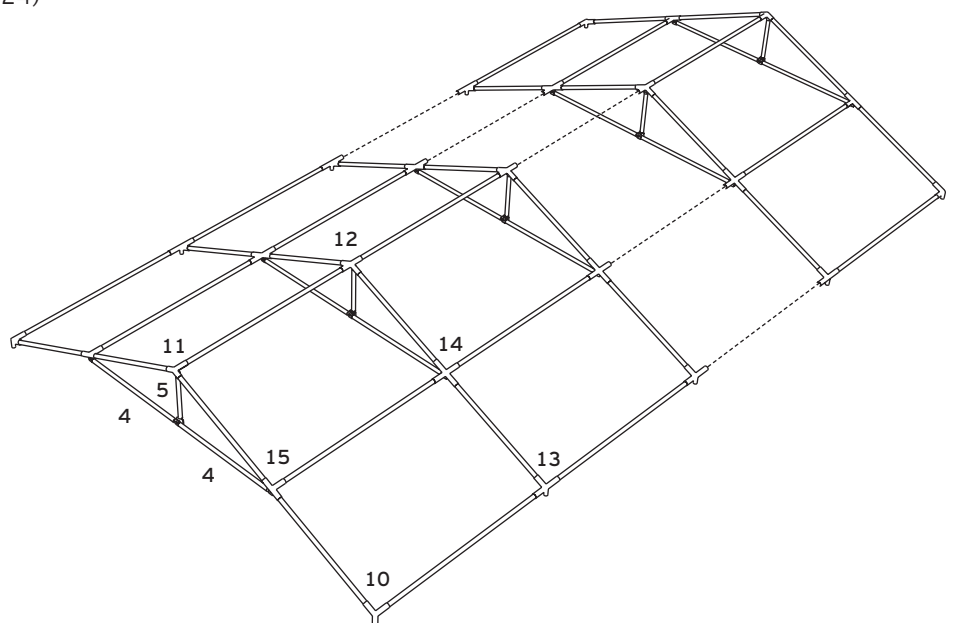

- 3** Hef één zijde van het tentframe op, en breng de benen (7) aan. Het been met nummer 8 moet telkens buiten in de vier hoeken worden geplaatst. Breng het dak (33) aan op het frame en bevestig het met de rubberen lussen (30). Let er op de rubberen lussen niet te strak te spannen, om het aanbrengen van de andere zijde niet te bemoeilijken.

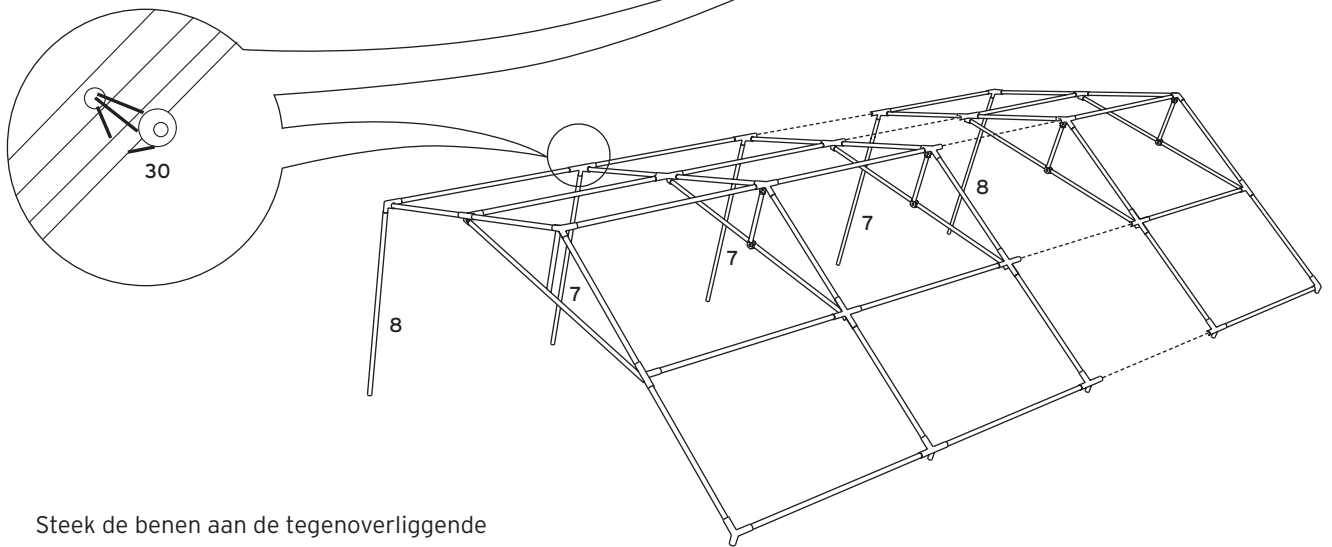
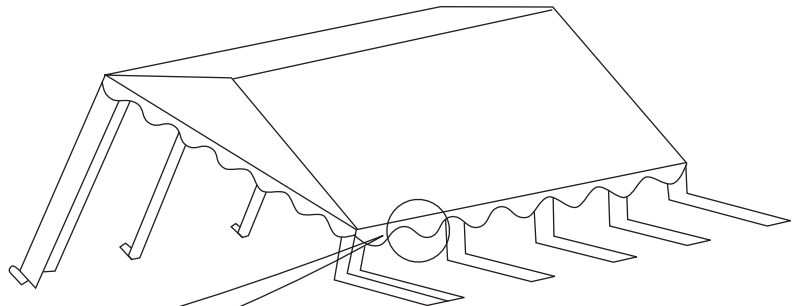

- 4** Steek de benen aan de tegenoverliggende zijde in en monteer de voeten aan het onderste uiteinden (16, 17). Gebruik de lange aardpennen (21) om de voeten aan de grond te bevestigen. De dakstroken worden met haken (32) aan de stangen (7, 8) bevestigd. Versterk de zijkaders door in elk van de vier hoekelementen dwarsstijlen (6) aan te brengen. Aansluitend vervolledigt u het vloerframe met de juiste stangen (2, 3 en 9) en verbindingen (18).

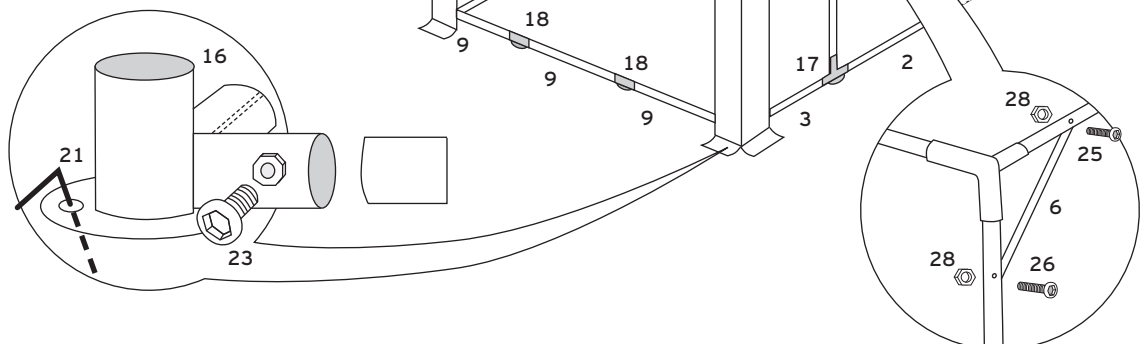
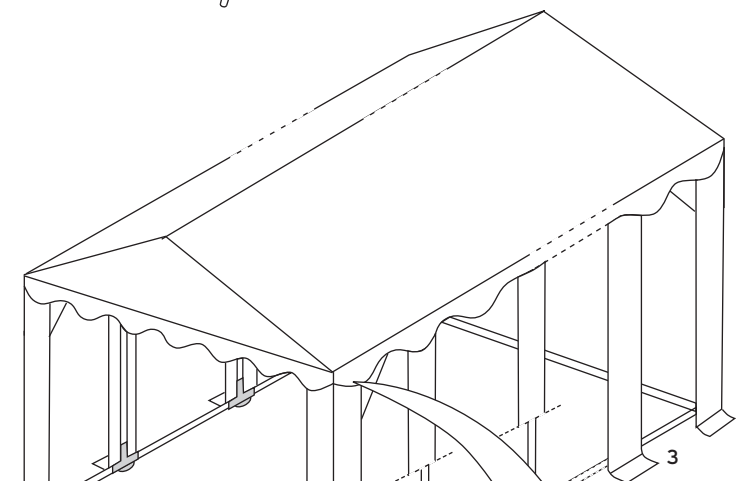

- 5** Spreid de zijwanden (34) en de eindwanden (35) uit en bevestig de zijwanden met de rubberen lussen (29) aan het frame en de eindwanden met de korte rubberen lussen (30) direct aan het dak. Met de korte aardpennen (22) bevestig u de eindwanden aan de ondergrond. Vanaf elke hoek van de tent vetrekt een spanlijn. Ze wordt met een schroefhaak (20) aan de grond bevestigd. Extra spanning resp. stabiliteit krijgt de tent door gebruik van de aardpennen (20).

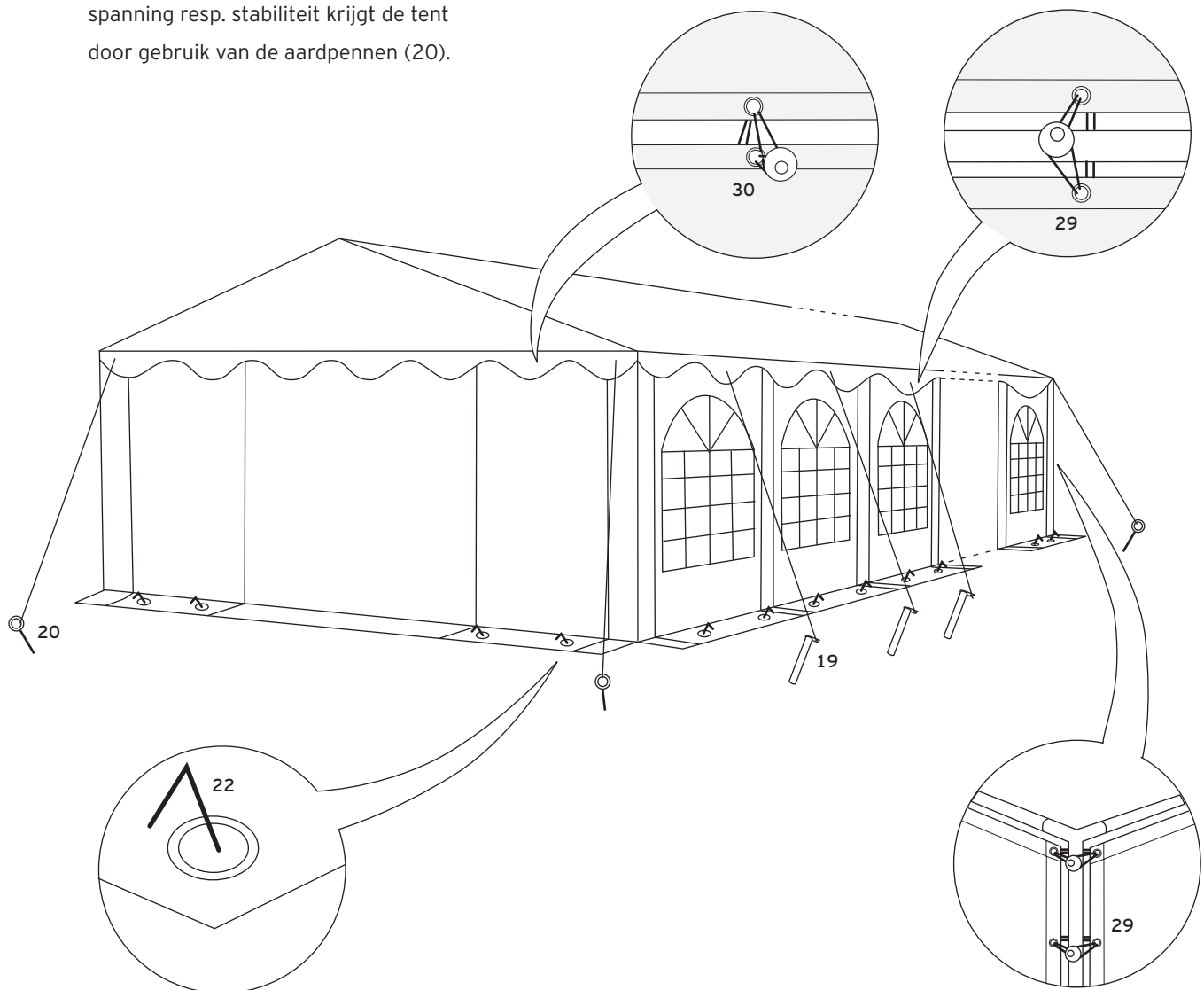

Reiniging en onderhoud













Dak en zijdelen kunnen met een zeepsoepje worden afgewassen. Schimmels en vochtvlekken verwijdert u met een zachte chlooroplossing. Volg de aanwijzingen van de fabrikant op, en test de chlooroplossing op een niet zichtbare plaats, om zeker te zijn dat er geen verkleuring optreedt.

Let op! De partytent mag niet in natte toestand worden gedemonteerd en verpakt. Laat haar voordien volledig opdrogen.

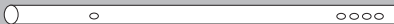

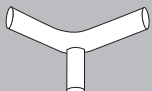

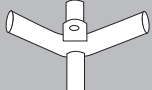
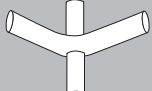

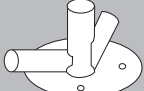
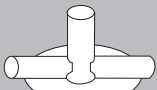



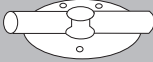

Waarschuwing

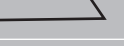
1. Let er op de tent voorzichtig te behandelen, om defecten te vermijden.
2. Niet te veel kracht gebruiken bij het hanteren van de stangen: ze kunnen anders beschadigd raken.
3. Tenten zijn bedoeld als tijdelijke beschutting en moeten bij slechte weersomstandigheden gedemonteerd worden.
4. Zorg steeds voor een aangepaste afstand tot slangen, gas- en elektriciteitsleidingen, om deze niet te beschadigen.
5. Bij gebruik van een geschikt verwarmingsapparaat (zie voor nadere informatie de vakhandel) moet een afstand van minstens 1,2 m tot om het even welk vlak worden aangehouden. Open vuur en verwarmingsapparaten met open vlam zoals terrasverwarmingen, gaskachels e.d. mogen in geen geval worden gebruikt.
6. De bouwer is verantwoordelijk voor een aangepaste verankering en daarmee voor de veiligheid van de tent.

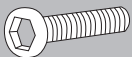
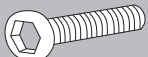
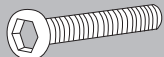
Contenu

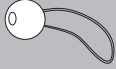
Code art.	Désignation	N° de repère		6x12m
30411	Tube 1430 mm 50-50	1		28
30513	Tube 1925 mm 38-38	2		38
30413	Tube 1925 mm 38-38 avec trou	3		4
30514	Tube 1470 mm Tirant de toit Série 6 horizontal	4		14
30515	Tube 500 mm Tirant de toit Série 6 vertical	5		7
30437	Tube 1174 mm 25-25 Tirant diagonal	6		4
30414	Tube 2488 mm 50-50 avec trous	7		10
30415	Tube 2488 mm 50-50 avec trous et un trou	8		4
30516	Tube 1915 mm 38-38	9		6
30416	Raccord 3 axes 110° 54-43	10		4
30417	Raccord 3 axes 140° 54-42	11		2
30418	Raccord 4 axes 140° 54-42	12		5
30419	Raccord 4 axes 110° 54-42	13		10
30420	Croisillon 54-42	14		10
30421	Té 54-42	15		4
30422	Raccord 3 axes - pied pour les coins 54-42	16		4
30423	Raccord 3 axes - pied pour les parois latérales 54-42	17		10

Contenu

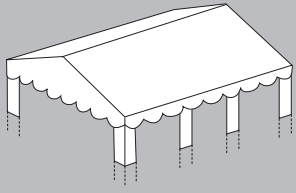
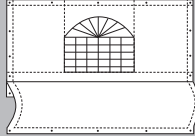
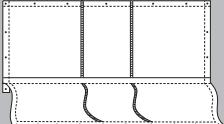
Code art.	Désignation	N° de repère		6x12m
30424	Raccord 3 axes - pied pour les parois d'extrémité 54-42	18		4
30436	Piquet de sol 60 cm	19		10
30044	Crochet à visser	20		4
30046	Piquet de sol 6x180 mm	21		14
30047	Piquet de sol 4x160 mm	22		54
30383	Vis 10 mm	23		184
30384	Vis 30 mm	24		28
30404	Vis 45 mm	25		4
30405	Vis 65 mm	26		4
30052	Écrou à oreilles	27		28
30407	Écrou borgne	28		8
30430	Boucle caoutchouc 14 cm type 1	29		196
30429	Boucle caoutchouc 5 cm type 1	30		26
30050	Cordeau tendeur 3 m	31		4
30051	Crochet de toit	32		14
	Toit	33		1
	Paroi latérale	34		12
	Paroi d'extrémité	35		2

Mode d'emploi

1 Cherchez un endroit où le sol est plan pour installer la tente. Déballez les cartons et vérifiez que toutes les pièces figurant dans la liste ci-dessus sont présentes.

Assemblez le cadre du toit en montant les pièces 10 à 15 sur les tubes (pièces 1, 2 et 3) et en bloquant les vis pour fixer le tout.

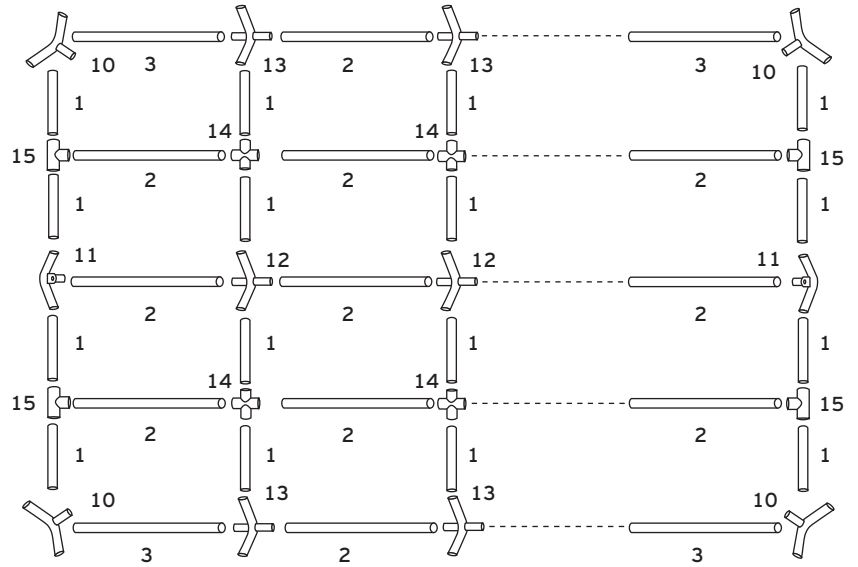

2 Fixez les tirants de renfort (pièces 4 et 5) au moyen des vis (24) et des écrous à oreilles (27).

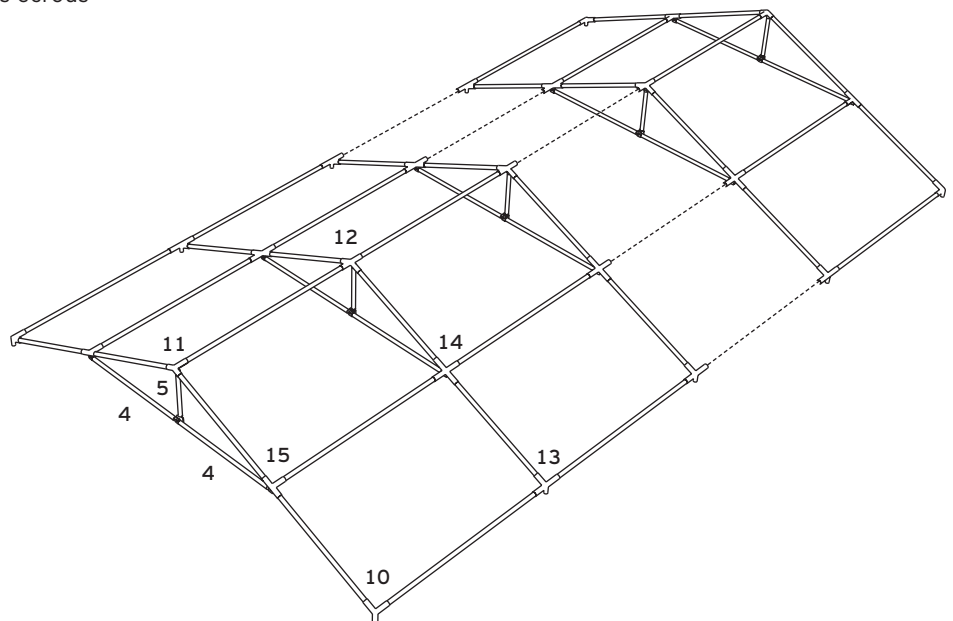

3 Soulevez un côté de l'ossature de la tente et emmanchez les montants (7). Le montant (8) doit toujours être installé à l'extérieur dans les quatre coins. Posez le toit (33) sur le cadre et fixez-le au moyen des boucles en caoutchouc (30). Évitez de tendre exagérément les boucles en caoutchouc afin de ne pas rendre le montage de l'autre côté plus difficile.

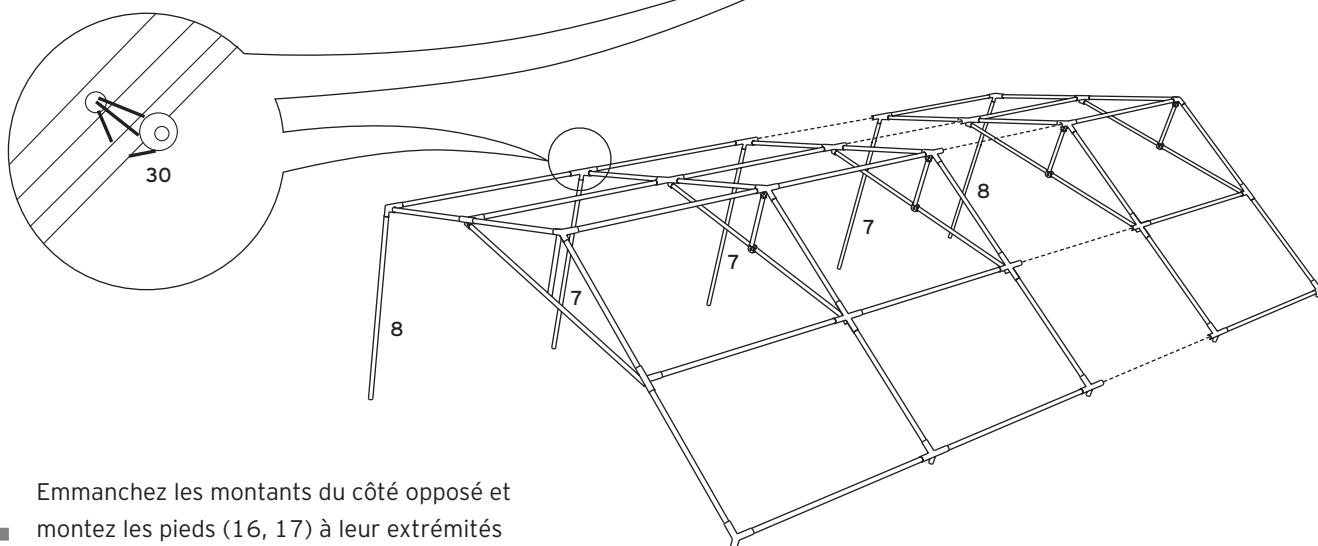
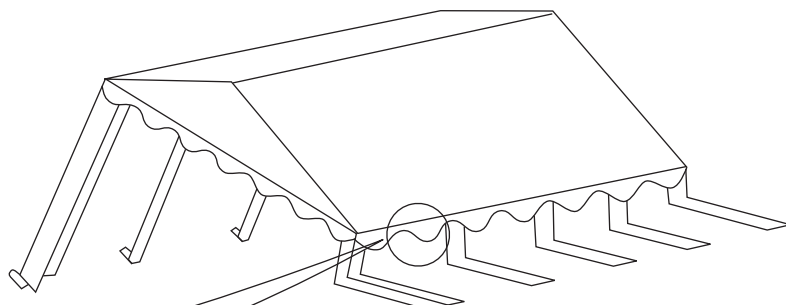

4 Emmanchez les montants du côté opposé et montez les pieds (16, 17) à leur extrémités inférieures. Utilisez les piquets longs (21) pour immobiliser les pieds au sol. L'habillage du toit se fixe aux tubes (7, 8) au moyen de crochets (32). Renforcez les cadres latéraux en montant les tirants diagonaux (6) sur chacun des quatre éléments de coin. Ensuite, complétez le montage du cadre de sol avec les tubes (2, 3 et 9) / raccords (18) correspondants.

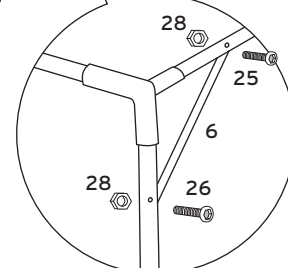
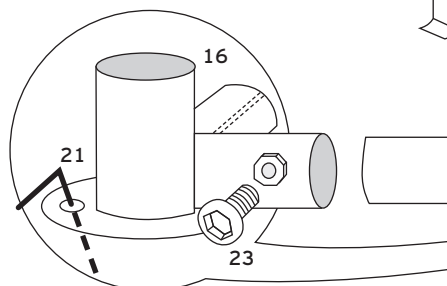
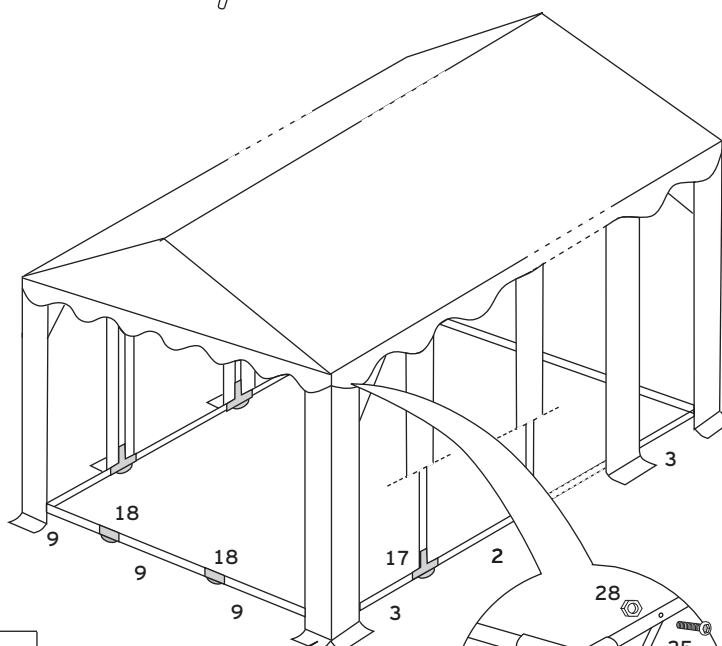

5 Écartez les parois latérales (34) et les parois d'extrémité (35) et fixez les parois latérales à l'ossature au moyen des boucles en caoutchouc (29) et les parois d'extrémité directement au toit au moyen des boucles courtes (30). Fixez les parois d'extrémité au sol à l'aide des piquets courts (22). Le cordeau tendeur part de chaque angle de la tente et il est tendu au sol au moyen des crochets à visser (20). Installez les piquets professionnels (20) pour tendre ou stabiliser davantage la tente.

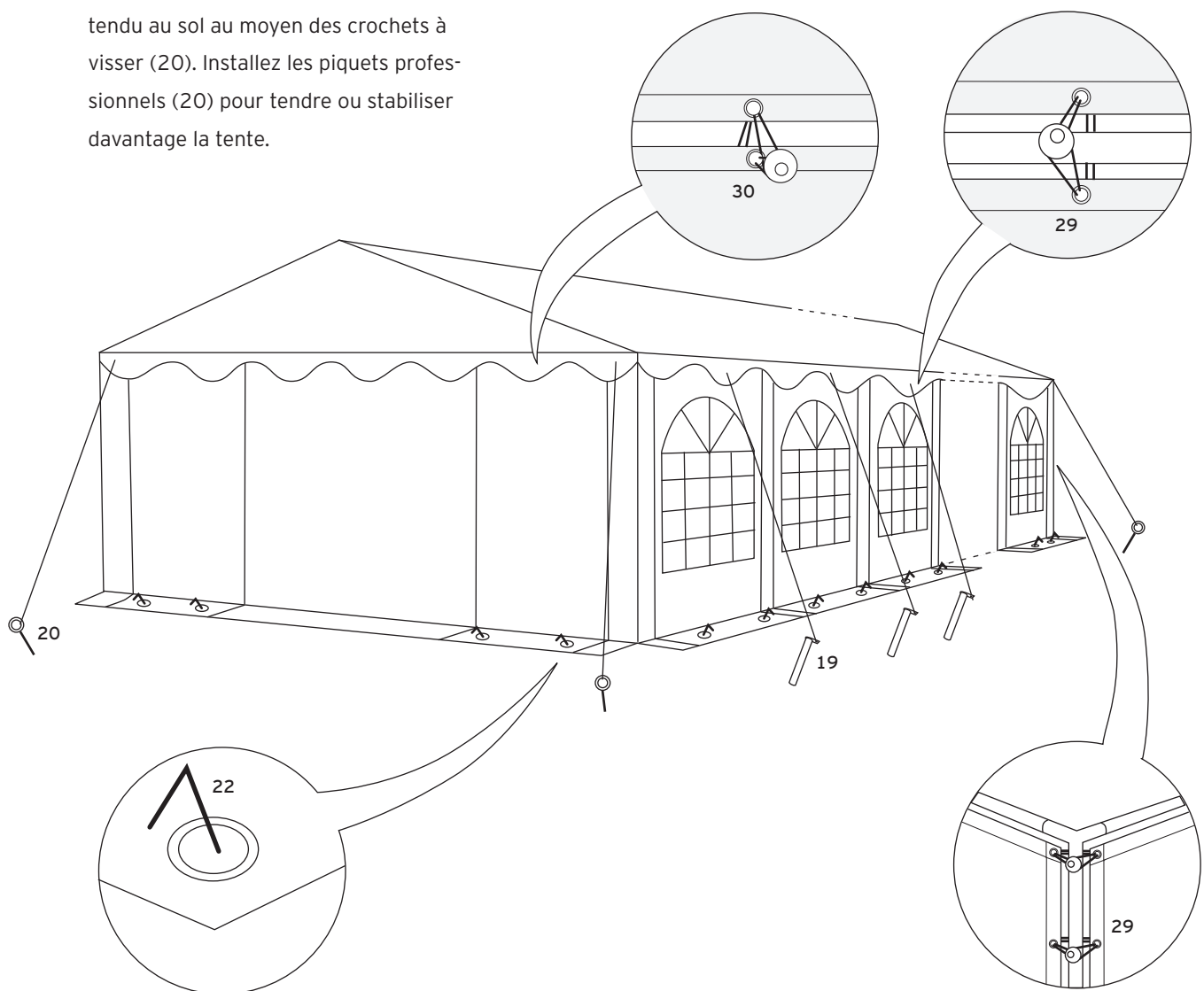

Nettoyage et entretien











Le toit et les parois se lavent à l'eau savonneuse. Pour éliminer les moisissures et les taches d'humidité, utilisez une solution légèrement chlorée. Suivez les instructions du fabricant et testez la solution chlorée à un endroit non visible pour vous assurer qu'elle ne provoque pas de décoloration.

Attention ! La tente de réception ne doit en aucun cas être repliée et rangée lorsqu'elle est humide. Laissez-la sécher complètement auparavant.

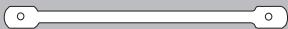



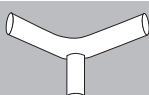
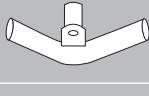
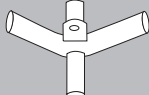
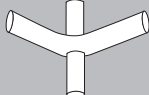

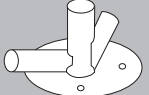
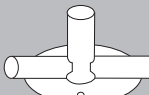



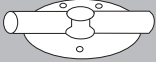
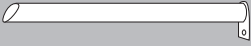

Avertissements

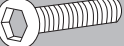
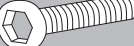
1. Veillez à manipuler la tente avec précautions pour éviter de la détériorer.
2. Évitez de forcer sur les tubes et les raccords, au risque de les endommager.
3. Les tentes sont destinées à des usages de loisirs temporaires et elles doivent être démontées en cas de mauvais temps.
4. Veillez à respecter systématiquement une distance appropriée par rapport aux tuyaux, aux conduites de gaz ou aux lignes électriques afin d'éviter de les endommager.
5. En cas d'utilisation d'appareils de chauffage adaptés (se renseigner par exemple auprès d'un vendeur spécialisé), respectez une distance minimum de 1,2 m par rapport à chaque matériau de bâchage. Les feux ouverts de même que les appareils de chauffage à flammes nues tels que champignons chauffants, radiateurs de terrasses, chauffages au gaz etc. ne doivent en aucun cas être utilisés.
6. L'installateur est responsable de l'ancrage adéquat et donc de la sécurité de la tente.

Obsah

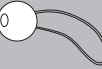
Č. výrobku	Popis	ID číslo		6×12 m
30411	Tyč 1430 mm 50-50	1		28
30513	Tyč 1925 mm 38-38	2		38
30413	Tyč 1925 mm 38-38 s otvorem	3		4
30514	Tyč 1470 mm Střešní výztuha Řada 6 horizontální	4		14
30515	Tyč 500 mm Střešní výztuha Řada 6 vertikální	5		7
30437	Tyč 1174 mm 25-25 Diagonální výztuha	6		4
30414	Tyč 2488 mm 50-50 s otvory	7		10
30415	Tyč 2488 mm 50-50 s otvory a s jedním otvorem	8		4
30516	Tyč 1915 mm 38-38	9		6
30416	Rohová spojka se třemi konci 110° 54-43	10		4
30417	Rohová spojka se třemi konci 140° 54-42	11		2
30418	Rohová spojka se čtyřmi konci 140° 54-42	12		5
30419	Rohová spojka se čtyřmi konci 110° 54-42	13		10
30420	Křížová spojka 54-42	14		10
30421	T-spojka 54-42	15		4
30422	Spojka se třemi konci – patka na rohy 54-42	16		4
30423	Spojka se třemi konci – patka na boční stěny 54-42	17		10

Obsah

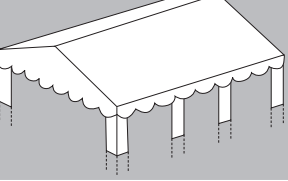
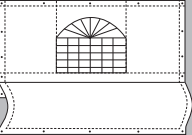
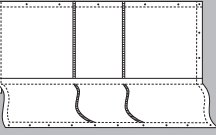
Č. výrobku	Popis	ID číslo		6×12 m
30424	Trojítá spojka – patka na koncové stěny 54-42	18		4
30436	Hřeby do země 60 cm	19		10
30044	Šroubovací háček	20		4
30046	Hřeb do země 6×180 mm	21		14
30047	Hřeb do země 4×160 mm	22		54
30383	Šroub 10 mm	23		184
30384	Šroub 30 mm	24		28
30404	Šroub 45 mm	25		4
30405	Šroub 65 mm	26		4
30052	Křídlová matice	27		28
30407	Kloboučková matice	28		8
30430	Pryžová smyčka 14 cm typ 1	29		196
30429	Pryžová smyčka 5 cm typ 1	30		26
30050	Napínací šňůra 3 m	31		4
30051	Střešní háček	32		14
	Střeška	33		1
	Boční stěna	34		12
	Koncová stěna	35		2

Návod k použití

1 Vyhledejte rovný poklad, na nějž stan umístíte. Vybalte kartony a zkontrolujte, zda obsahují veškeré zde uvedené díly.

Složte rám střechy: díly 10 až 15 namontujte na tyče (díly 1, 2 a 3) a důkladně je připevněte pomocí šroubů.

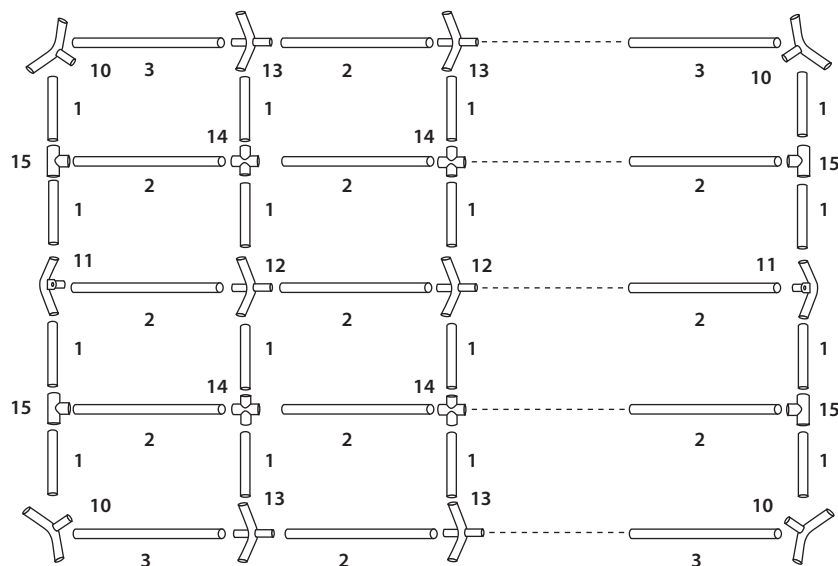

2 Pomocí šroubů (24) a křídlových matic (27) připevněte zesilovací výztuhy (díly 4 a 5).

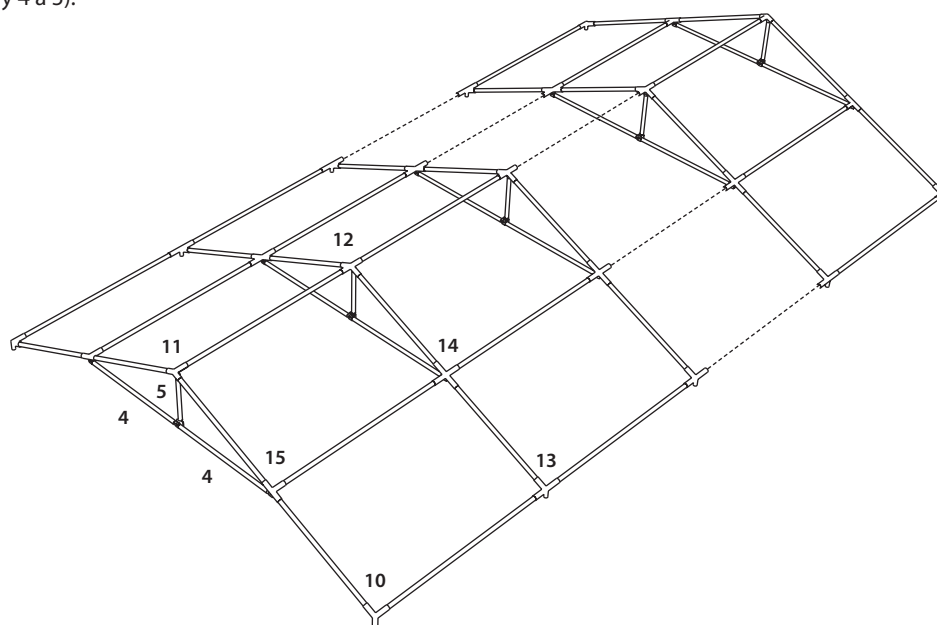

- 3** Nadzdvihněte jednu stranu kostry stanu a nasadte na ni nohy (7). Noha s číslem 8 se vždy musí nasazovat vně – do rohu. Položte na rám střechu (33) a připevněte ji pryžovými smyčkami (30). Dejte pozor, abyste pryžové smyčky nenapnuli příliš, a neztížili si tak instalaci druhé strany.

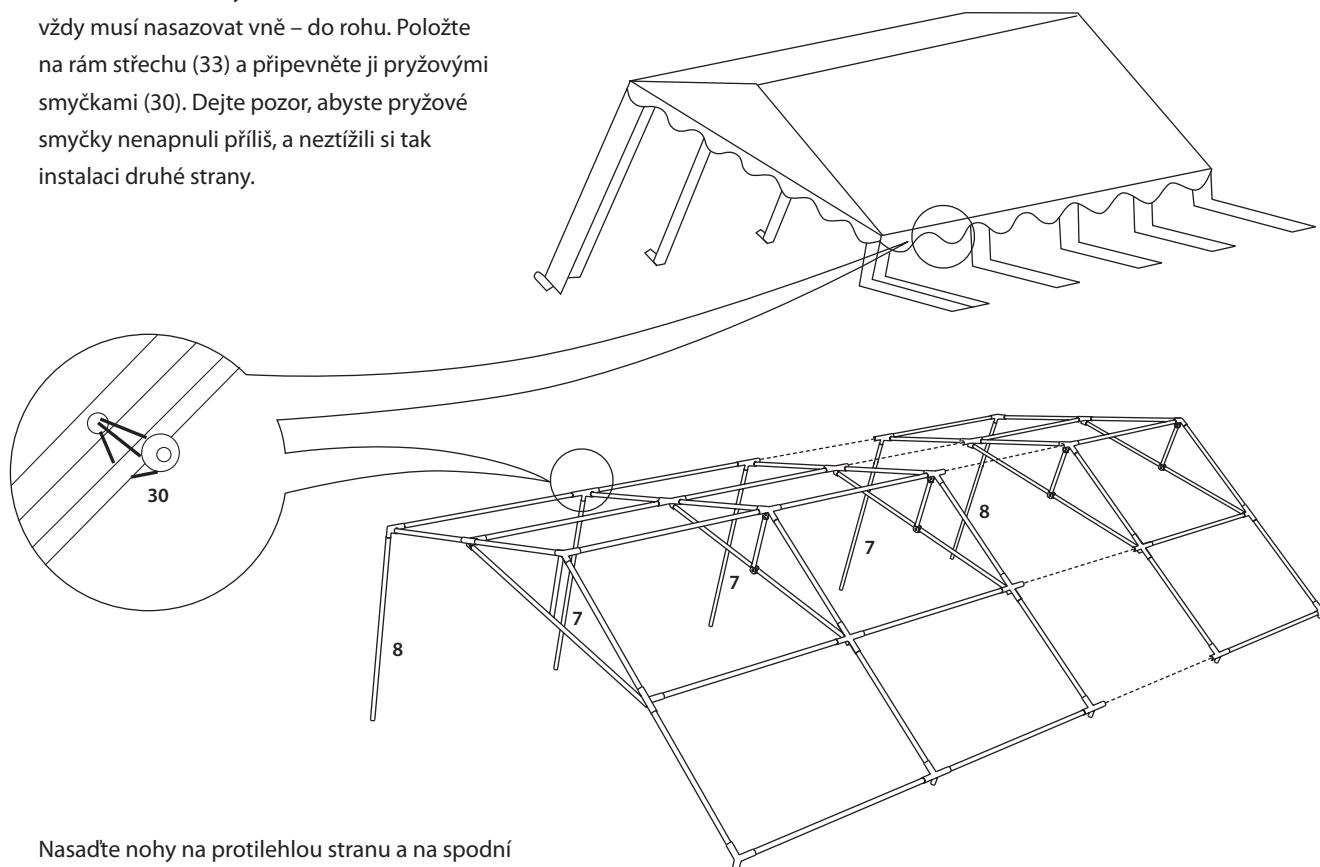

- 4** Nasadte nohy na protilehlou stranu a na spodní konec namontujte patky (16, 17). K připevnění patek k zemi použijte dlouhé hřeby do země (21). Střešní lemy připevněte k tyčím (7, 8) pomocí háčků (32). Zesilte boční rám: ke všem čtyřem rohovým prvkům připevněte příčné výztuhy (6). Spodní rám následně doplňte příslušnými tyčemi (2, 3 a 9) a spojkami (18).

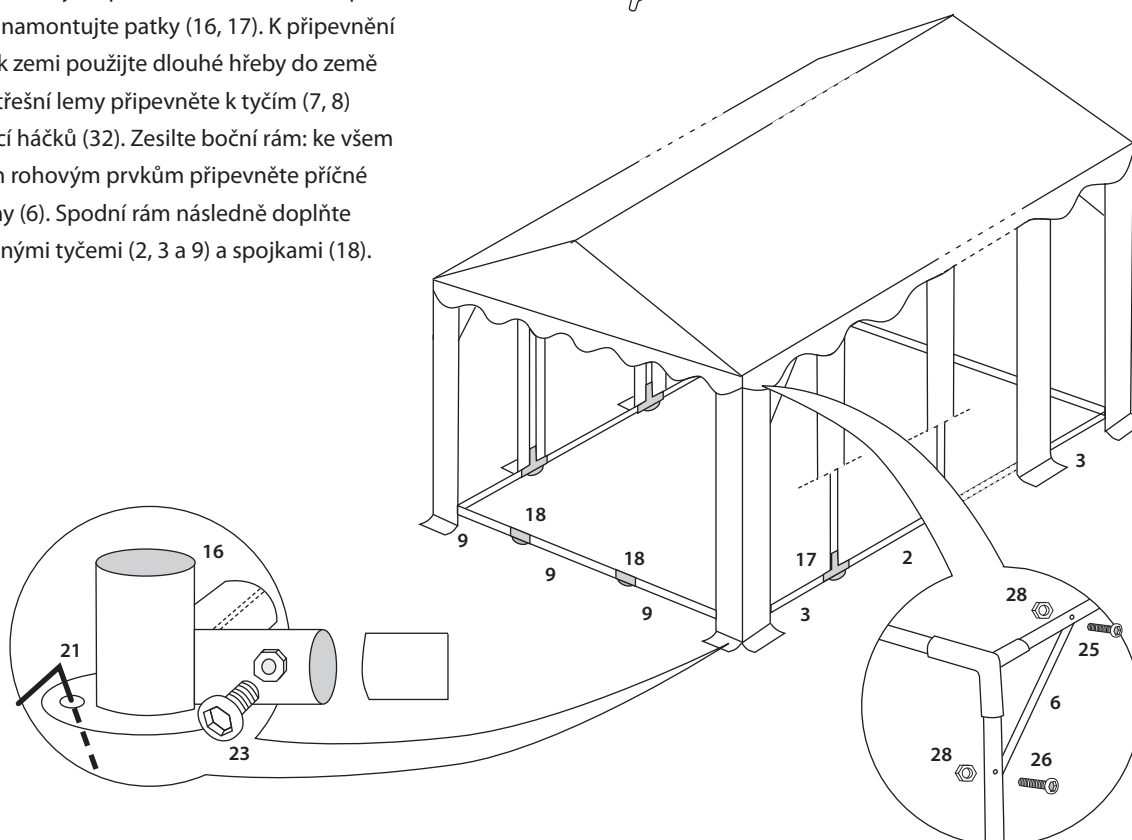

- 5** Rozprostřete boční (34) a koncové stěny (35). Boční stěny připevněte pryžovými smyčkami (29) ke kostře, koncové stěny pak krátkými pryžovými smyčkami (30) přímo ke střeše. Pomocí krátkých hřebů do země (22) připevněte koncové stěny k zemi. Napínací šňůra se natahuje z každého rohu stanu a k zemi se kotví pomocí šroubovacího háčku (20). Dodatečné napnutí, resp. stabilitu získá stan použitím profesionálních hřebů do země (20).

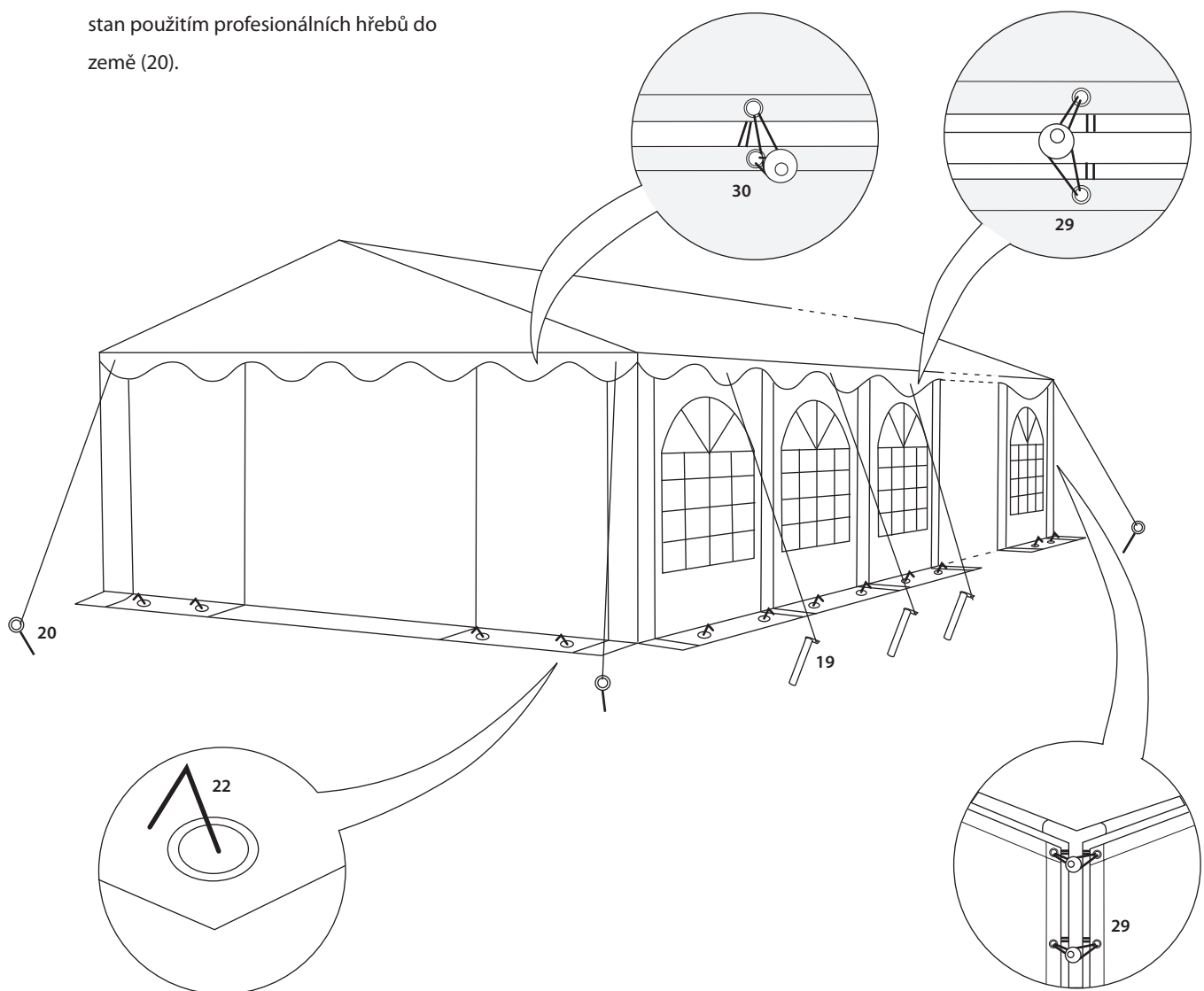

Čištění a údržba

Střechu a boční části lze omývat mýdlovým roztokem. Plíseň a skvrny vzniklé vlhkostí odstraňujte jemným chlorovým roztokem. Dodržujte pokyny výrobce a chlorový roztok nejprve vyzkoušejte na místě, které není vidět. Tímto způsobem se ujistěte, zda nedochází ke změně zabarvení.

Pozor! Party stan se nesmí skládat ani balit ve vlhkém stavu. Nechejte jej před tím zcela vyschnout.

Varování

1. Se stanem manipulujte opatrně, předejdete tak jeho poškození.
2. Na soutyčí nepoužívejte nadměrnou sílu, jinak by mohlo dojít k jeho poškození.
3. Stany jsou určeny k dočasnému pobytu a neměly by se sestavovat za nepříznivých povětrnostních podmínek.
4. Vždy udržujte vhodný odstup od hadic, plynového a elektrického vedení, aby nedošlo k jejich poškození.
5. Při používání vhodných topných těles (informace získáte například ve specializovaných obchodech) dodržujte minimální odstup 1,2 metru od plachty. V žádném případě byste neměli používat otevřený oheň a topná tělesa, která otevřený oheň využívají, například topné hříby, terasové sálače, plynová topidla atd.
6. Sestavující osoba odpovídá za přiměřené ukotvení, a tím pádem za bezpečnost stanu.